

Naturalistic Landscaping

***Kansas State University
Agricultural Experiment Station
and Cooperative Extension Service***

“I went to stay at a very grand and beautiful place in the country where the grounds are said to be laid out with consummate taste. For the first three or four days, I was enchanted. It seemed much better than Nature, that I began to wish the earth had been laid out according to the latest principles of improvement. In three days’ time I was tired to death; a Thistle, a heap of dead bushes, anything that wore the appearance of accident and want of intention was quite a relief. I used to escape from the made grounds and walk upon the adjacent goose common, where the cart ruts, gravel pits, bumps, coarse ungentlemanlike Grass, and all the varieties produced by neglect were a thousand times more gratifying.” —Sydney Smith

Landscaping is the arrangement of plant material using its form, texture and color to create special effects. Good landscaping can create a sense of privacy or a feeling of being somewhere special.

The above statement does not make a distinction between ornamental plant material, with which we create ornamental landscapes, and indigenous or native plant material of the natural landscape.

This section is aimed at helping people who build a home on a site which has a natural landscape. Following these ideas you can maintain the character of the site and enhance the home with naturalistic landscaping. In this type of landscaping, the difference is in the choice of plants, (trees, shrubs, groundcovers, vines, flowers, grass), to create a habitat in which fauna takes an active part.

Maintenance is associated with landscaping, mowing, pruning, fertilizing and replanting. It has always been a part of any ornamental landscape. With careful selection of ornamental plant material, maintenance can be minimized. With naturalistic landscaping, maintenance can be further reduced. Through the increased understanding of our native landscape, we increase our awareness and understanding of our natural environment.

Native Plants

Some people may think indigenous plant material is coarse and unattractive. Those who know native plant material look forward to its diversity. They enjoy clusters of prairie rose with its soft pink petals and deep red buds, clumps of butterfly weed with its brilliant orange flowers, the deep red sumac leaves in the fall, as well as redbud and many other flowering trees and shrubs.

The purist may want to use only indigenous plant material. This approach can be satisfying, but it is not necessary if care is taken when selecting from ornamental plant material. Remember that many of our cultivated plants find their origin in wild ones.

Therefore, if on a small, open space of prairie you would plant the ornamental crab apple—keeping form, texture, and color in mind—you would increase scab disease resistance when the selection is made from Asiatic crab apples. This species is superior in disease resistance to our native types.

With the intrusion of a home on a natural site, there are automatically small areas created closer to the home which lend themselves to more cultivated species and varieties. The challenge is to select plant material so carefully that it may go unnoticed. Keep in mind that a certain boldness in landscape design with a departure from classical rules may give the finest

results and provide the most pleasure. A home standing on the “prairie” with one old apple tree can create a living environment. A house in the woods with a winding trail among the tree trunks leading away from the house and returning to a patio in the sun also creates a living environment.

The selection of plant material and the creation of plant communities is difficult and calls for understanding. Mistakes can and are made, but by studying native plant habitats you can learn to create similar plant communities. (Figure 1)

Placing Your Home on the Site

More serious mistakes are made with the initial selection of the building site and the architectural design of the house than with the actual selection and composition of plant materials. People often will destroy the uniqueness of the site by putting their dream home on that particular spot which gives the site its uniqueness and appeal. Study your site—analyze why you like it, and then ask yourself the question, “If I put my house here plus the driveway, will I still enjoy this spot?” We forget that the appeal of the site comes from an arrangement of plant material or topography. By building a house in the wrong place, the feeling is suddenly destroyed. We now look to the house, and we look from the house through its windows over the site in many directions, but the original character of the site is gone. It is sometimes advisable to build the house on another spot to be able to enjoy that “something” as seen from the patio or out of the windows. On the plains where we enjoy the view, the uniqueness of the site may be the view. Homes are often built on top of a ridge or on a spur for this reason. Even here, caution is in order. A home situated below the crest may fit in better, allowing you to walk to the top of the hill and leaving it as a pleasant experience.

The beauty of any view will wear thin if looked at constantly. We do get used to views. It is the refreshing experience, the anticipation of things to come, which gives us joy.

Careful siting of the home is extremely important. Keep in mind any road which would have to be the connecting link between your home and the county road systems. The road should be layed out with the topography, grade and the character of the site in mind. It should be layed out “with the land.” The grade should be easy and the location so that a curve hides the home and allows a pleasant surprise. A straight road through hilly topography causes scars on the land which take a long time to heal. The result is steep banks on either side of the road. Those surfaces with southwest exposure will be extremely dry and, depending on the soil, very difficult to reestablish with plants.

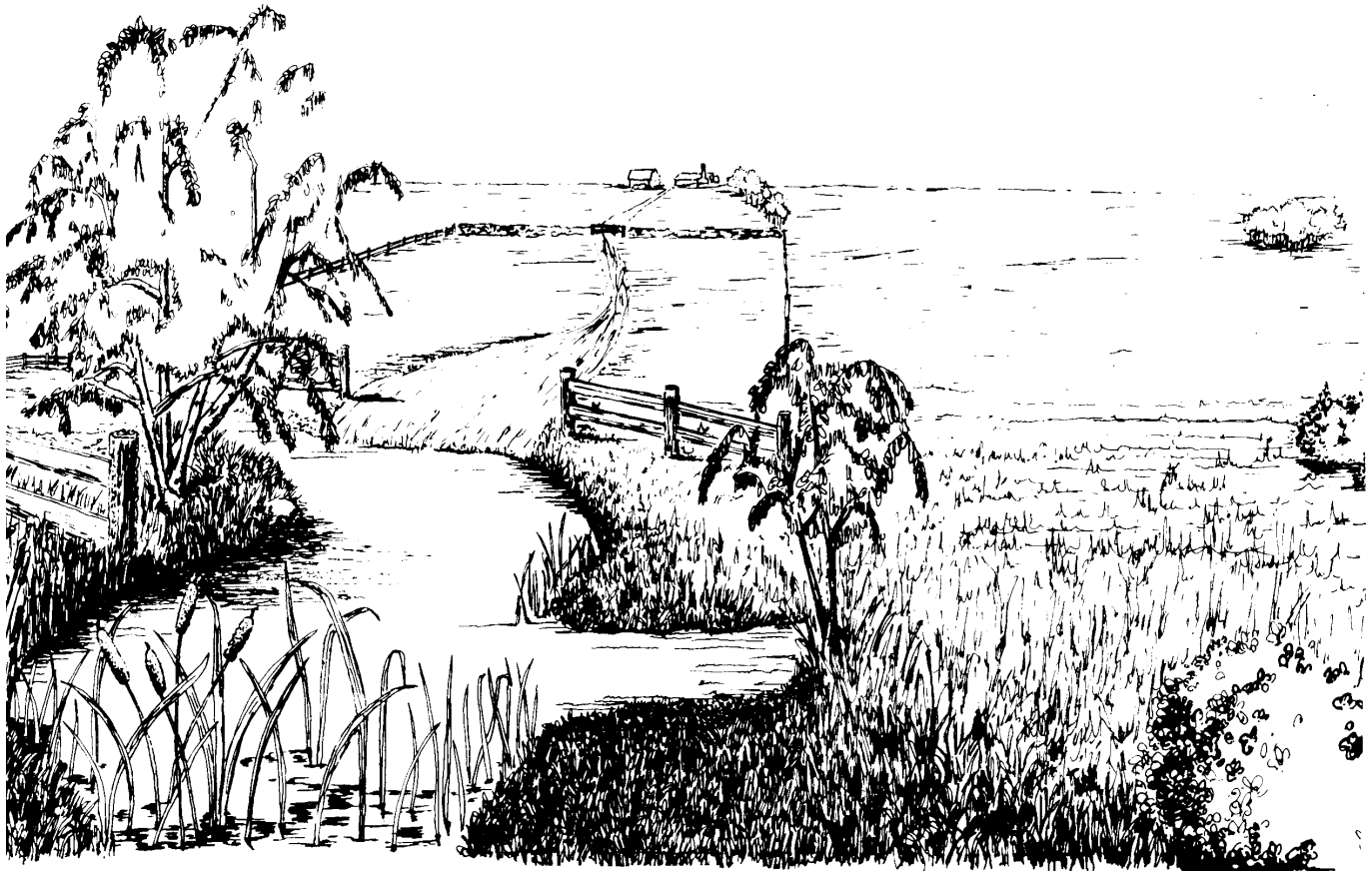

Prairie Pond

Emerging Vegetation

Willow Fringe

Prairie

Figure 1. There are many different plant communities from prairie pond to upland prairie.

At the same time the actual building site is selected, you should have the architectural style of the home in mind. Many unique sites have been ruined because a style of home was built which did not fit or complement the site.

Let us consider a home at the end of a ridge. It overlooks a slowly winding river with trees bordering the stream as well as growing along the gullies. The area is bordered by rich agricultural land with deep, loamy soils which provide a calendar through the seasons because of plowing, planting and harvesting. We have a quilt-like landscape of patterned fields, growing crops, and in the distance a town. All of this is surrounded by the hills. On such a site, the home should blend in, and a two story square home would be out of place because of its dominant imposing roof line. The roof line of any home built on such a site should follow and blend in with the lines of the hills.

You have many options to choose from in the selection of building materials. By selecting the material carefully, a strong association between site and building can be attained. On a very stony, rocky site, the use of limestone can create a strong bond between home and site. This bond can be weakened through improper use of the rock. It should be remembered that limestone was deposited and can be seen

along the road with beds layed horizontally, and that is the way it should be used in construction to fit in best and provide the bond between home and land. Such rock used on edge may seem very decorative, but it appears unnatural and destroys the effect needed most; i.e., fitting an intrusion in the natural landscape in the least noticeable way.

Besides stone, which would be most expensive, wood comes closest to the natural material which very likely surrounds the house. If wood is used, the effect of belonging can be destroyed through careless selection of exterior paints. A pink or deep blue painted house in a natural setting is difficult to accept. However, there are colors which do fit in better, and some classical colors, such as barn red, may be considered. In Norway, bright barn red is used over much of the countryside to paint both barns and homes. There are many stains to choose from, and they are very effective in blending the wood exterior in with the natural site.

You may argue that brick is made of clay and what could be more earthy. Indeed true, and brick can be considered for building material. Here, as with paint, care should be taken that the color and texture of the brick helps to blend the home into the site and does not make it stand out awkwardly.

Roofs

The roof is an important part of a home. A wooden shingle roof gives a home extra character in the same way that a thatched roof does for an English cottage. It is sad that costs often force us to look towards cheaper materials. When other roofing material, such as asphalt, is used, the choice of color is wide open. Select a color which blends in with the landscape. Depending upon the site, you may choose from light yellow and brown textured, after the prairie, to darker colors. The lighter colors give the greatest reflection of the sun's rays and reflect heat during summer months.

There is something very satisfying and earthy about being able to touch the roof. Think about some low roofs you've seen. In designing the roof lines of the home, you may want to keep this fact in mind. Casually, through design, make it possible to touch the roof at least at one place.

Looking at Windows

Careful location of the windows and their size is important. The picture window has been an architectural disaster. It shows too much at once, and therefore, nothing is seen. Treat the views from your house carefully. Select what you want to see, what you want to show. Decide what you want shown or seen later or during special events and locate and arrange your windows accordingly. A tall tree's height is emphasized when seen through an upright, narrow window. A small, roughly circular pond may be more interesting when seen through a circular window.

In short, take the time to think about all the effects your structure will have on your senses.

When you feel that you cannot make all the decisions yourself because the problem is too complex, do not hesitate to hire professionals. The money invested in the right architect, landscape architect, and nurseryman may make the difference between creating a unique place to live and destruction of a beautiful site.

Using Your Imagination

Once you have established where and what to build, you must project your imagination to the landscape of the site and decide how to develop it. Making the most of it depends on your creativity and the character of the landscape.

The urban lot is quickly and, often unimaginatively, divided into the public, the private and the service area. A natural area does not allow



Figure 2. An old tree stump supporting plant and insect life.

such rules to be imposed. In a natural area there are many unusual places and niches, and each should be understood, developed and maintained. For instance, a fallen tree, partly decayed and giving life to fungi is such a spot. (Figure 2) It can be made into a place to sit, to rest, or to look out over a field. (Figure 3) The more diversified the site is, the greater the diversity of places and the greater the amount of learning you will need to understand the challenge of each niche. The greater the variety of scenes, the more interesting the landscape is visually. This should not indicate a need for creating more scenes than there are, but does encourage making the most of all available ones—small and large. By scenes, we mean landscape or view observed from a certain location.

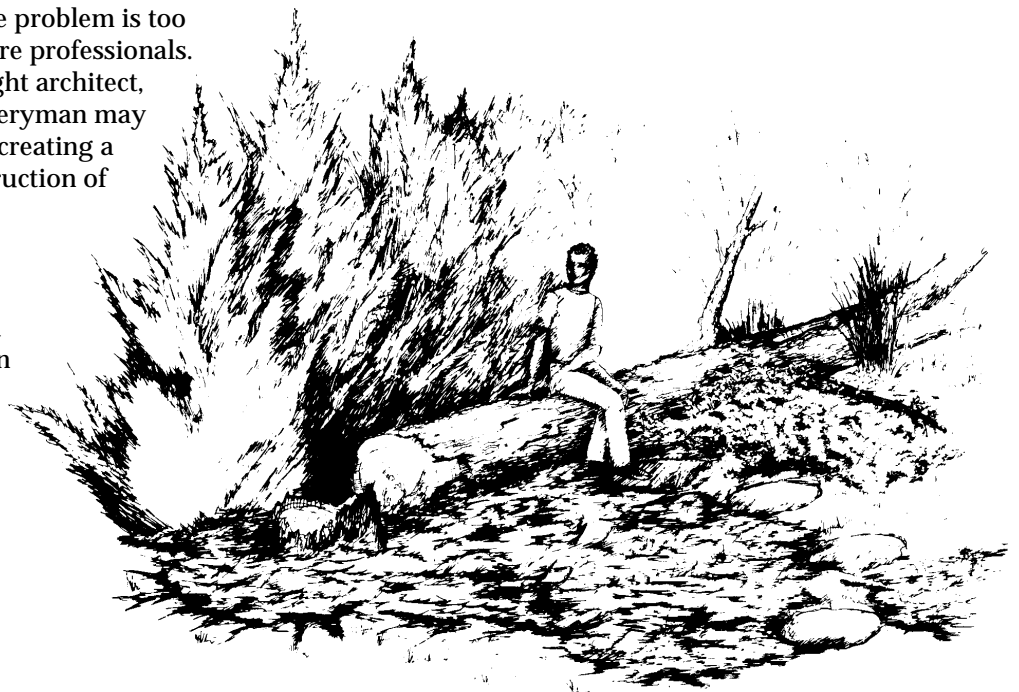

Figure 3. Creating a place to sit.

Mass and Void

These scenes are generally established through the presence of mass and void. (Figure 4) Mass being the hills, a group of trees, a building, or a singular tree. The void being a valley, a river, prairiefield or an open space between buildings. The arrangement of mass and void gives us the setting which we sense as a special place. The feeling we get may be good or bad, positive or negative. This depends much on the arrangement of the voids and spaces. The arrangement is expressed through a line more or less sharply defined at ground level where the two meet. This line is one of the most forceful expressions and can be defined on paper.

All of us experience lines. It may be the straight and rectangular lines of the grid system over our midwestern landscape expressed through our roads and fences, or flowing lines defined by our meandering rivers. In the natural landscape, most lines are flowing. They often are influenced by the contours of the land and the soil formation. A beautiful, horizontal line running through many parts of the Flint Hills is the flinty rock outcrop seen near the surface of the hills protruding out of the sod cover. The slowly eroding hill exposes this rock pattern in a unique and striking way and can be followed for miles meandering along the hills.

Because lines are so important, we will take a closer look at them to understand their force. (Figure 5)

Flowing Lines

Although it is true that a straight line between two points is the shortest distance, it is seldom the most interesting. (Figure 5) And, the careful use of curves in the landscape be it a driveway, flagstone path, or the line separating lawn from flower and shrub border is one way to add interest to form.

A segment of a circle provides us with a curve. (Figure 5A) Depending on the size of the circle, the curve will be more or less sharp. The curve which is less sharp provides us generally with a more pleasing flowing line. (Figure 5B) On the other hand, a short, sharp curve can add interest to a line, (Figure 5C) but don't over use it.

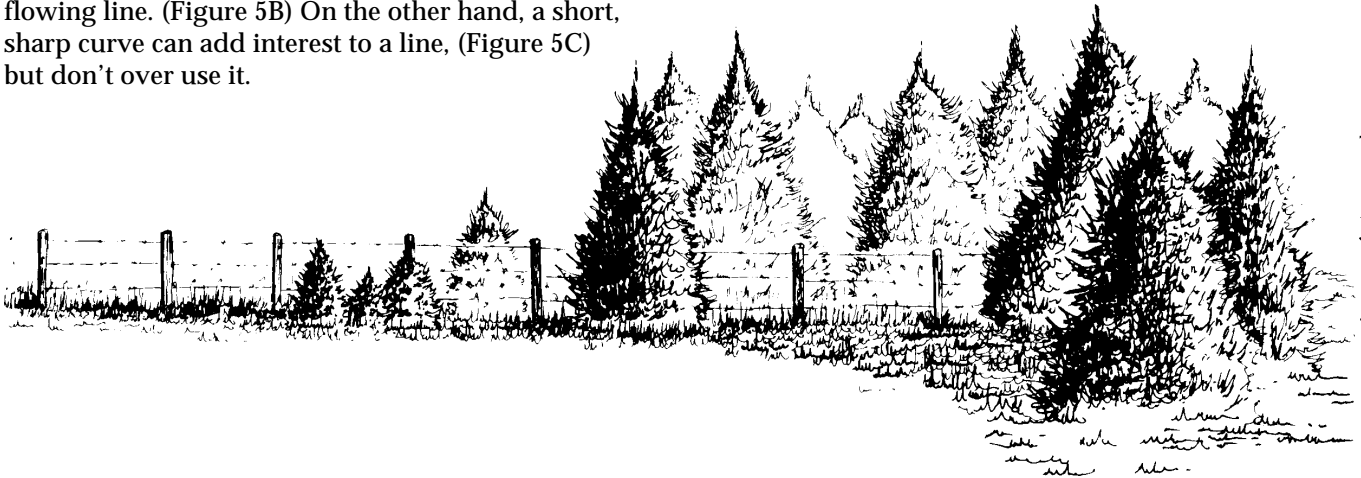

Figure 4. Open space, group of trees, void—mass.

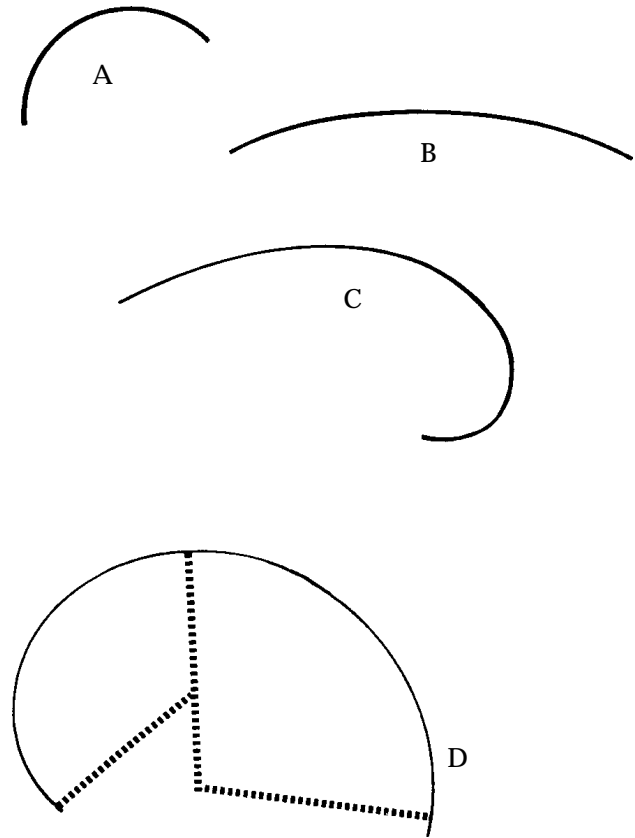

Figure 5. Lines have “character.”

Two different curves, one large and one small, joined together create a combination of curves which can be used to connect lines gracefully. (Figure 5D)

Two curves flowing in different directions create a reverse curve. (Figure 6E)

When a short, straight line is planned in between where the two curves meet, the feeling of flow is improved. (Figure 6F)

Perhaps the most challenging line in a natural flat prairie landscape is a mowed walk leading through

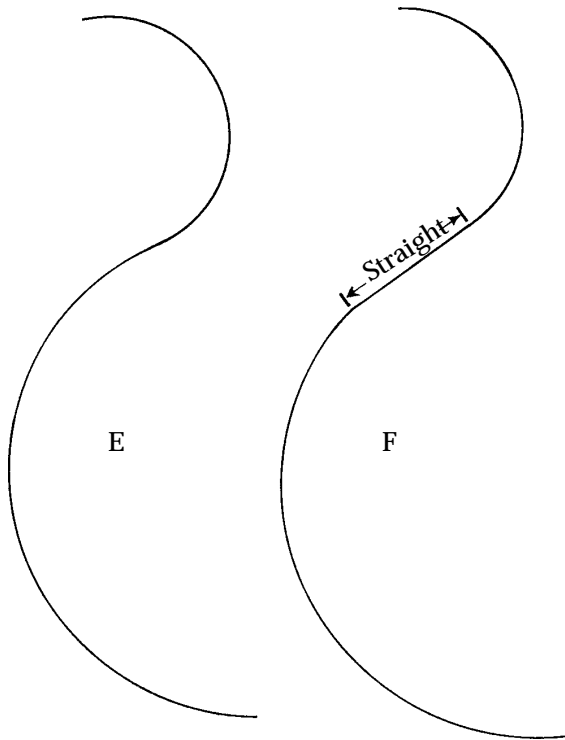

Figure 6. The creation of attractive lines through the use of straights, curves and tangents.

the prairie. Such a walk with the purpose to invite one for a walk should be layed out on the above principles with flowing compound and reverse curves making the most of the slight contours of the land. (Figure 7)

In the landscape, we also observe other lines, i.e., the lines of wires of a fence, the top of a hedge, the outline of a clump of trees, the line along the horizon. (Figure 8)

Through plant material, the vertical line or silhouette can be modified and made more interesting. The vertical line changes as plant material is allowed to develop and grow. Shearing and clipping will not be



Figure 7. A mowed path in the prairie; an invitation for a walk.



Figure 8. There are many lines in the landscape—some manmade.

used in naturalistic landscaping. The change can be controlled to some extent through selection of slow-growing species and varieties, but the aim of any design should be toward a visual climax—a maturity which may take some years to be accomplished and, of course, will always be influenced by natural forces—such as drought, rain, ice, storms, lightning as well as insects and disease which should or should not be controlled depending on one's attitude.

Having established that vertical and horizontal lines exist, the challenge is to create that visually exciting landscape. (Figure 9) In the rolling prairie landscape, the natural plant form follows the topography of the land. (Figure 10) The plant composition also rolls. But interestingly enough, our native red cedar does provide a rather striking form when standing in a small clump or alone. (Figure 11) The pyramidal form can help us create a feeling of change in elevation greater than there actually is. The aim is to create landscape variety.



Figure 9. The plains.



Figure 10. Rolling prairie with rolling plant forms. A group of plants below the crest tends to flatten the landscape.

If only one upright cedar is to be used, it is important that from the main point of view the tree does not appear to be precisely on the top of the hill. It should preferably be at the far end to increase depth. A shorter, perhaps prostrate juniper, can be planted in the foreground accentuating the height of the upright cedar and providing increased sense of distance. On the other hand, by placing small shrubs in masses in front of hills, their height seems to be lowered which would reinforce strong horizontal lines.

Trees and shrubs can help to enframe a view. (Figure 12) Through partly obscuring the view, it can be made a more intense experience. Location of trees and shrubs should be done carefully and the effect should be natural. Sometimes trees obscure a view, and one is rash to remove the whole tree when on closer observation it is only the low hanging branches which need to be removed. When removed, the tree suddenly enframes the view. (Figure 13)

The Kansas landscape is more varied than many people think. There are distinct differences noticeable while moving through the state as expressed in our physiographic regions. In time, over most of Kansas, an agricultural landscape was imposed on the natural landscape. The appreciation of this cultural landscape as developed over a period of time will help those who build on the edge of it to make the most of its features. Although different than the natural landscape, the agricultural landscape also provides many scenic

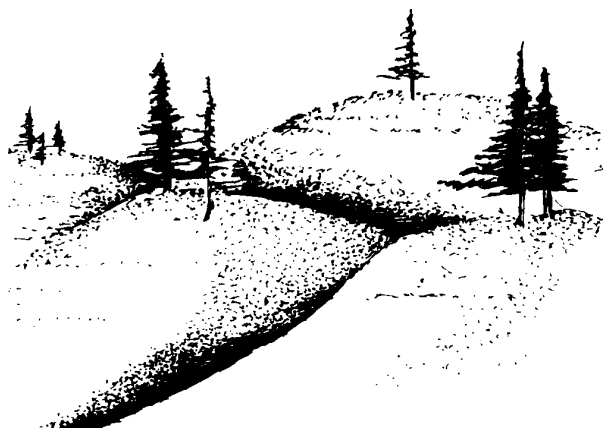

Figure 11. On the other hand, cedars on top of a hill emphasize height.



Figure 12. Plant material can enframe a view making it stand out more.

variations and creates many habitats. We can still find old stone walls, partly tumbled down and overgrown, and hedge rows. (Figure 14) When farmers had to take time to lay field stones as walls, the results were beautiful and intriguing. For those who want to restore a section rock wall, a method is to lay large stones in a double row so that they slant slightly toward the center which is then filled with smaller stones. As the stones settle and compact, the walls become more and more solid and better able to withstand pressure from weather, man and animals.

The hedgerows, once common in the landscape, are the living fences and windscreens. Where hedgerows grow, the rate of evaporation is lowered, the humidity is increased, and temperature changes of both air and soil are modified. The character of the hedgerow is made up by its flora and fauna. In spring, serviceberry produces a mass of star-like flowers and wild plum provides an abundance of white bloom. Honeysuckle and brambles show new leaves with bright green color. Raspberry and blackberry brambles and wild roses create a prickly thicket made impenetrable and a good habitat for insect-eating birds. Catbirds, chickadees, and slate-colored juncos fly back and forth. From tree tops the cardinals proclaim their territory. Underlying the bird song is the hum of insect activity. Butterflies, bees and many other insects go to flower after flower. On the ground, among the dried leaves of past autumns, ants and beetles find their niche. In the web of life, they provide food for birds and garter snakes. (Figure 15) Cover is provided for pheasant and quail which share the space with small animals such as rabbits, weasels, squirrels, chipmunks and mice.

Naturalistic Landscaping in an Urban Setting

We have taken a look at naturalistic landscaping on sites where the setting is already available and the important aspect is not to destroy indigenous, natural-growing plant material. What about the urban home, number 13 down the block, where all houses face the street and the lawn mowers compete with each other.



Figure 13. Low branches and underbrush can obstruct a view. Do not remove too much at once. Step back frequently and look. Suddenly a view is created.

Is it at all possible that more naturalistic landscape can be created and yard maintenance be reduced by observing and studying small native plant communities? The answer is that it can be done but it takes patience and good use of imagination.

One of the first aims should be to reduce the lawn. These extensive man-made monocultures which change species and varieties at the property line are time, water and energy consuming. Lawns use fertilizer which is expensive. Upkeep of lawns requires water which is rapidly becoming a precious resource. To mow the grass, power mowers are most commonly

used which consume fossil fuel and, in the process, add to noise pollution. The larger self-propelled mowers use even more resources. They not only consume more fuel but their manufacturing requires additional resources. Limiting the use of power



Figure 14. The old rock wall—part of our cultural landscape. Blend it in with your landscape.

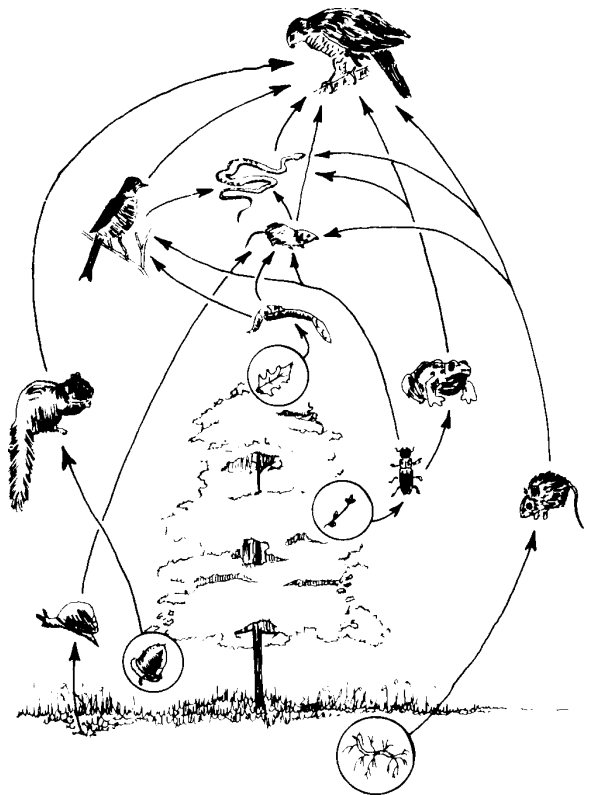

Figure 15. The web of life. A food chain from plant life to a red-tailed hawk which only preys on small animals for food.

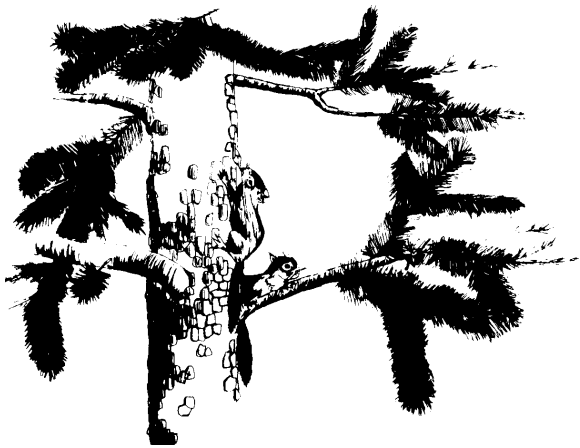

Figure 16. Create a landscape with plants which can be rich in fauna; young squirrels in a Scotch pine.

mowers is in order. Naturalistic landscaping is one way to achieve this goal. The pay off is the creation of a more interesting and richer landscape in many suburban areas. On the suburban lot, often all traces of naturalness have been erased, plant material has been removed, the slope of the land has been altered and additional fill has changed the soil horizon. Start with creating a private outdoor area in front of the house by screening of the road through mass planting of trees, or cedars, semi grouped together. Create plant compositions. The success and possibility of such an approach depends on where you live in Kansas. As a

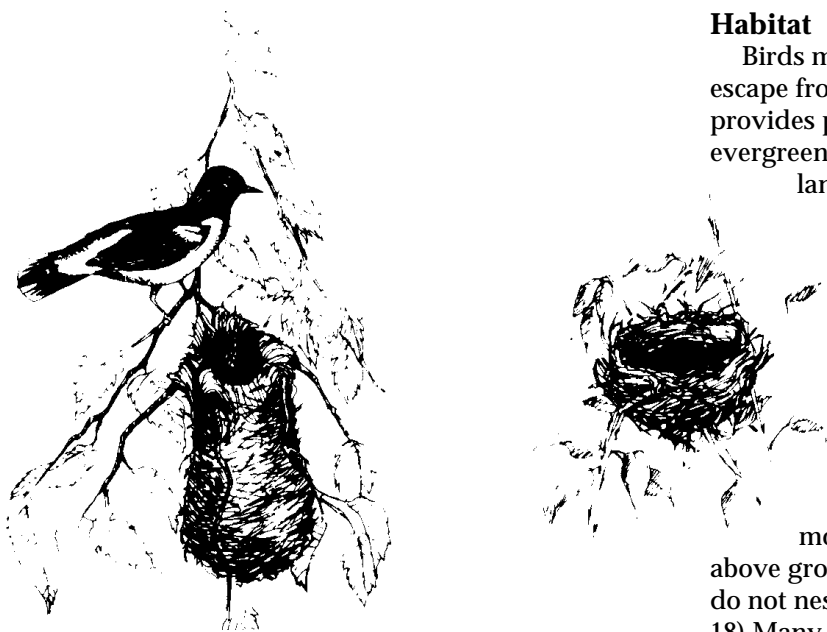

Figure 17. Birds need different nesting sites for their different nests. Look for the Baltimore oriole in groves and shade trees. The nests can usually only be found after leaves have fallen and birds are gone. Nest of the cardinal has no leaves in its foundation and is lined with grass. These nests are seen most often in shrubs.

guide you can study native plant material near your home and try to reconstruct its composition. Where taller trees will grow, use ample understory smaller trees to create a rich and varied edge effect. Allow the “foundation planting” to grow away from the house, leaving only a small lawn area to be mowed. The pleasing, flowing lines take you along a path to the backyard where a similar arrangement on a larger scale can be created. Even if you do not want to be crowded by taller plant material, it is not necessary to mow the total yard. It can be aesthetically pleasing if the “manicured” lawn runs into an unmowed prairie where wild flowers such as hare bell, butterfly weed, Nebraska lupine, daisies, and other native flowers are allowed to grow and go to seed. Besides the flowers in Kansas, the diversity of grasses can be especially beautiful through the seasons. This way the expense of back lawn may be reduced considerably and a far more interesting and livelier landscape created with habitat provided for fauna. (Figure 16) Songbirds will be attracted and future maintenance will be minimal.

A tree and shrub identification guide will be helpful in identifying existing plant species. Create vistas and plan for accent points as seen from patio, windows and along miniature trails.

Song birds are well worth planning and planting for. Birds with their colors and habits can add much interest to the landscape. There are three essentials for birds which must be considered when planning for them.

Habitat

Birds must have protective cover. Cover helps them escape from cats, dogs, and natural predators and provides protection during bad weather. Dense evergreens effectively supply this protection. When landscaping especially to attract birds, plants are placed closer together than normal.

Thicket like plantings such as wild plum are ideal as the branches grow close to the ground. This dense vegetation growth also provides nesting sites. (Figure 17) Most song birds require medium height, dense cover. This is one reason for creating the intermediate shrub layer between trees and ground cover. The average nesting height is around 8 feet with most nests situated between 5 feet and 20 feet above ground. With some exception, most songbirds do not nest in tall trees or low ground cover. (Figure 18) Many bird food plants selected for shrub borders also provide privacy and screen unsightly view. Mass plantings are desirable and often can help to reduce maintenance.

Birds like variety. Keep this fact in mind when you create a plant composition. Plant a rich intermingling of species, sizes and shapes of plants. (Figure 19) Lay

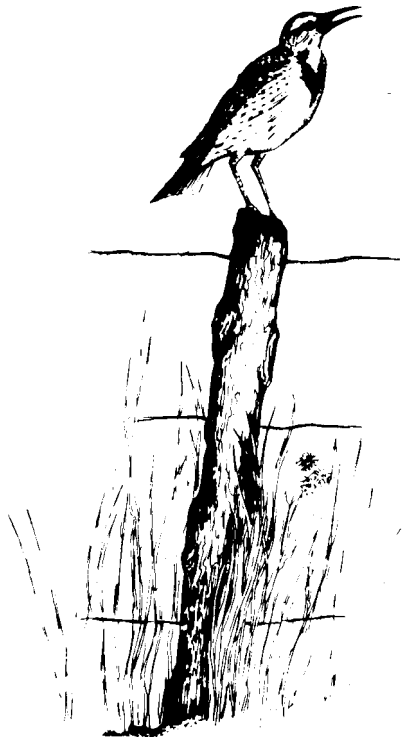

Figure 18. The western meadowlark needs undisturbed grassland. The mower invites the robins. The meadowlark is one of the few birds nesting on the ground.

out your plantings in varied patterns. Although most song birds nest in shrubs, do provide them with a wide choice for their various activities. If you have a wooded area, a small clearing lends variety to the habitat of birds. The horizontal and vertical three-layered plant pattern resembling the structure of a natural community is very attractive to look at and ensures diversity of song birds.

By studying the plants already present in your general plan for landscaping, you can bring in a diversity of plant forms including fruit-bearing trees and shrubs for understory. Yards and grounds that have only deciduous trees and shrubs are improved by the addition of junipers, cedars, yews, and other evergreens. These will provide shelters, especially during winter.

At all times, think about being able to see the birds. Place plants so that birds using them can be observed from a window. Carefully prune trees so that perching branches are at the correct height.

Food

A continuous supply of food is essential for all birds. (Figure 20) Those plants that retain their fruits into the winter are especially important. Plants producing fruits and seed during the summer serve as a supplement to a bird's insect diet, and those retaining color add interest to the winter landscape. (Figure 21) The desirability of an area for birds is not only en-



Figure 19. Through use of varied plant material, you can attract different birds; hummingbird hovering near trumpet vine—an aggressive climber.

hanced by permitting underbrush to grow but also by allowing the layer of rotting twigs and leaves to accumulate. Dead limbs, even dead trees, should not be removed for they play their part in the web of life.

To escape the harshness of winter and the shortage of food, many bird species migrate. Many birds travel through Kansas on their way to and from their wintering areas.

Water

Water must be available. (Figure 22) The water should be shallow, at least along the edge of a container. A small supply of water can be maintained during winter through use of an electric heater. When you build a small pond or pool, border it on the contour with shrub masses. Also, plant clumps of shrubs and evergreens well back from the water. Willows are especially attractive to orioles, warblers

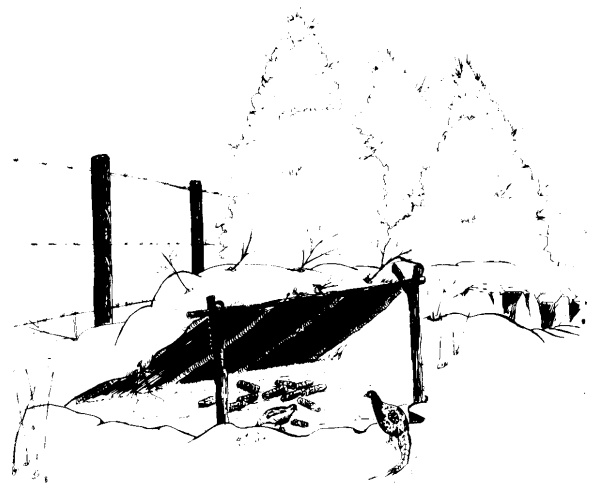

Figure 20. A feeding station for quail and pheasants.



Figure 21. Plant trees and shrubs which produce fruit to attract song birds.

and catbirds. The red-winged blackbird is found near the water's edge often nesting in the reeds. Some birds such as meadowlarks and field sparrows like the open areas of natural grasses and wildflowers. You can keep such areas free from woody plants through occasional mowing. The aim should be a natural grass and forbes stand, not a mowed lawn. The latter attracts robins and keeps the meadowlarks away. Remember, there are enough short mowed lawns already!

The above are the three essentials for birds. To attract more birds, it helps to put up bird houses and feeders. (Figure 23, 24) Bird houses should be protected from cats and squirrels. If you feed birds during the winter, be sure to do so through the entire winter because birds become dependent on this food source.



Figure 22. Birds need water.

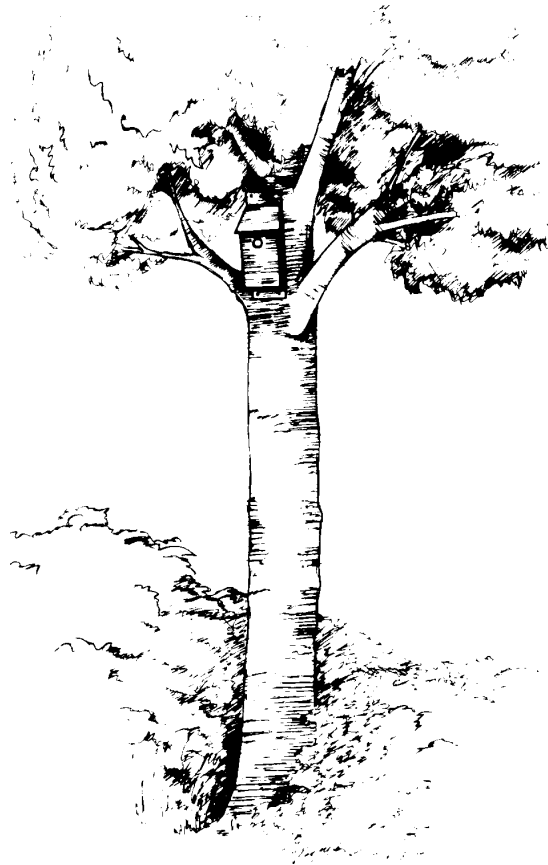

Figure 23. Bird houses can help attract more birds, but they should be spaced to provide territory when using. One type of box to attract more than one of a species. See page 23.

Birds are not only interesting to watch and study, but they play their part in controlling insect populations. As incalculable as the host of insects eaten by many birds is the mass of seeds, chiefly those of noxious or undesirable weeds, which they consume. The true seed-eating birds such as finches and doves, subsist chiefly by digesting the concentrated store of

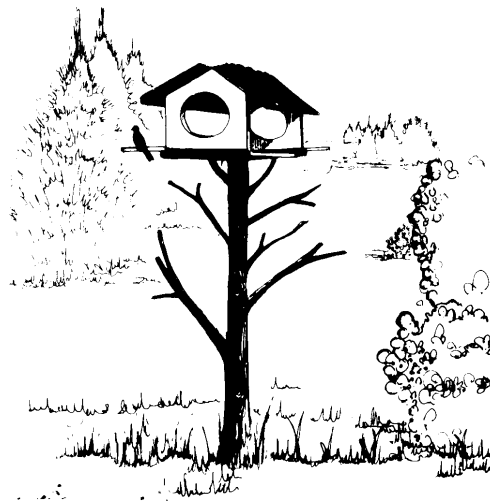

Figure 24. A birdfeeder providing perching in the pecking order!

plant foods within the seed. Thus, the vitality of the seed is destroyed, and any residue passing from the bird is generally incapable of sprouting and growth. Birds which take fruit and berries, on the other hand, frequently regurgitate the hard kernels of the fruits, such as the pits of the cherries or seeds of poison ivy or pass these elements through the digestive track unharmed. It is in this way that seed of cedars and many other plants are spread to encroach upon open fields or to appear along a fence row or in a hedge.

An easy, although sometimes a slow, way to establish a hedge row of bird-attracting shrubs is to attach one strand of wire to a row of stakes following a pleasing curved contour line, along one side of the driveway. When the ground under the wire is prepared through rototilling or disking, the birds perching on the wire supply the prepared soil with their droppings which contain a collection of pits and seeds. Upon germination these seeds will create the new hedge. (Figure 25)

Birds protect themselves from over populating an area by establishing territory. In planning a naturalistic landscape with the aim to attract song birds, this fact should be understood. Bird pairs are spaced over a terrain through aggressiveness of male birds towards others of their species and sex. The males claim territory. Territory reduces interference with pairing,

nest building, and rearing of young. Ownership of a territory provides more or less a monopoly of the food resources nearby and of nesting materials.

The male cardinal flying from tree top to tree top during spring singing his song is claiming his territory. Birds which fail to obtain territory form a group from which replacements come in case of death to owners of territory.

One special note on bluebirds which suffer from the aggressiveness of house sparrows and starlings. Where man has cleared all dead stumps and removed all natural nesting places, bluebirds will take to bird boxes. When locating the boxes, keep in mind that bluebirds prefer open areas with scattered trees. Boxes should be mounted three to five feet off the ground. Fence posts make good support. Spacing boxes at least a hundred yards apart prevents fighting among the highly territorial bluebirds. The bluebird box should have an entry hole 1½ inches wide. This will stop the starlings but not the sparrows which must be evicted.

Landscape Principles

Anyone who starts to create or modify an existing natural landscape should be aware of the evolution of a natural and cultural landscape as well as the basic principles of design. These principles once understood can help make sound natural landscaping decisions. The principles follow.

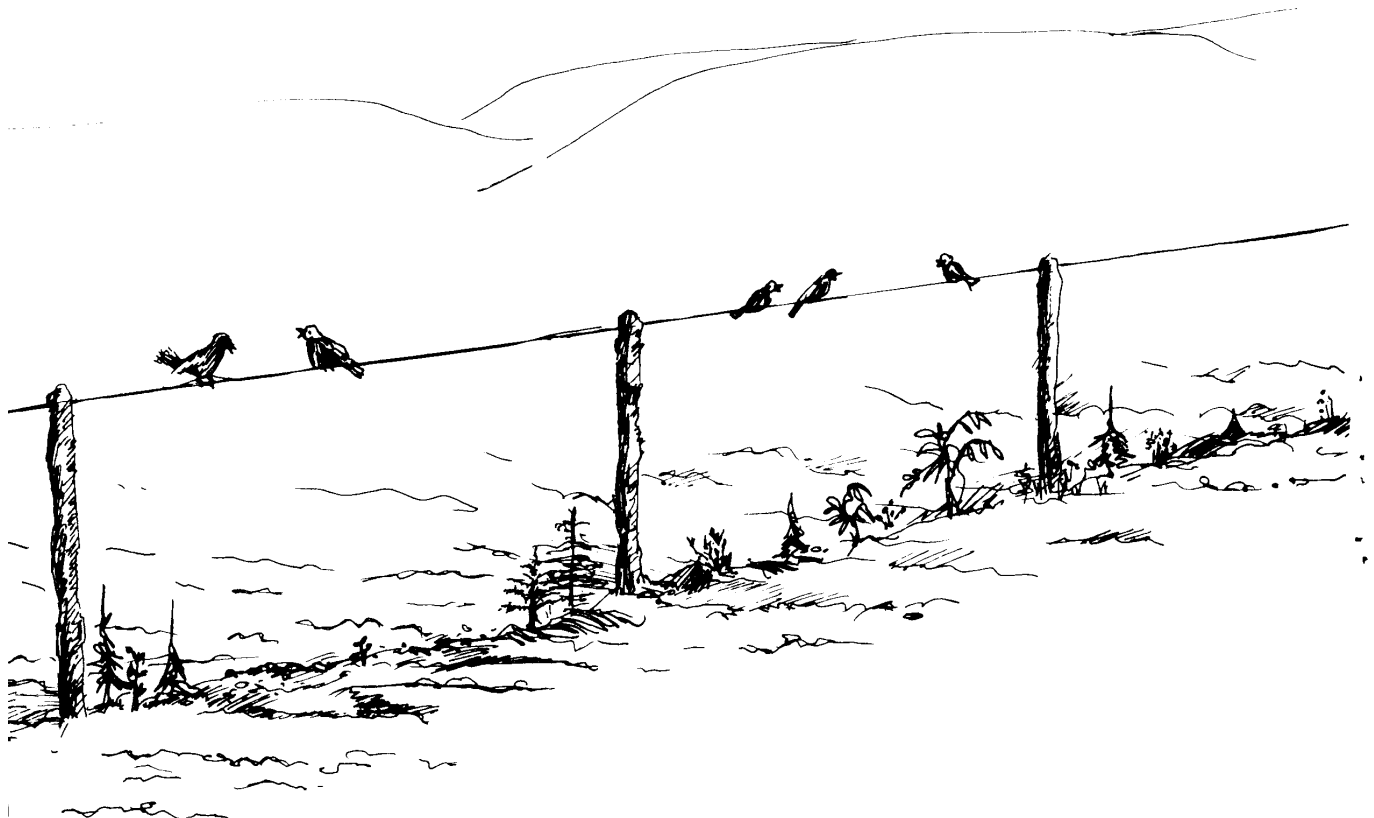

Figure 25. A simple way to establish a hedge row.

Proportion and Scale. A pleasing relationship should exist between the three dimensions of length, breadth and height. Balance: Accents are carefully distributed over an area, without necessarily spacing them equally each side of an axis.

Unity. The component parts, each being a pleasing feature, fit together to form an equally pleasing whole.

Elegance of line and shape. Lines are designed so that they are pleasing; curves are not interrupted. The eye should be carried from one part to another fluently. When a designer wants to create or control patterns, he does so by making use of lines. These lines may be expressed through paths, rock walls, fences, and change of plant compositions. In a landscape composition, a carefully planned group of lines will direct the attention of the viewer to a particular area of interest. Lines are also useful in controlling movement. Straight lines suggest movement without hesitation. Interconnecting straight lines create points at the intersections for hesitation, as crossroads do. Meandering, curved lines invite slower movement and are best used in areas that are as natural as possible, such as a nature path.

Contrast and Harmony. Lines flowing harmoniously together are very pleasing to observe, on the other hand, bold contrast of a curve with a straight line can be very interesting. When selecting plant material, the contrast of fine foliage with coarser, rounded outlines with vertical or spiked growth, the harmony of blended flower and foliage color and the sharp contrast of white flowers against red, or yellow against purple is effective.

Emphasis. Through the use of emphasis, the eye is directed to one portion or object of the composition. Secondary points of emphasis may be used where the eye is directed towards plants or other landscape features that have less contrast with the overall composition than the primary point or area of emphasis. Vertical elevations on the plains are obviously dramatic, more so than in other landscapes. Their emphasis value is very high.

Variety. A critical element in design is variety. Too little variety leads to monotony. A very fine balance between extremes produces a pleasant sense of unity in a landscape composition.

Repetition. Repetition gives the element of variety meaning and expression. A variety of lines, forms, textures and colors is needed to create an interesting landscape, but this does not mean that every shrub and every tree must be different within a design. Repetition is usually achieved by placing individual plants in groups or masses of a single species. In a large scale landscape, these masses of varying sizes may be repeated.

Form. A composition will be more attractive when plants are used that are natural looking and graceful

when they are fully grown. The trunk, branches and leaves together create the form of a tree. The different plant forms we recognize are: columnar, round, vase, weeping, pyramidal, oval, and irregular, but not all of these will work on the Plains. Generally, if the plant is tall, it is said to have a vertical form. When a group of vertical plant forms are placed together in large enough number so that the length of the group is greater than the height, then the mass of plants has a horizontal form, as in a windbreak. This is very suitable for use on the Plains to establish a relationship in the natural landscape between plant forms and topography. The basic form of the topography is repeated in the native plant materials. On the Great Plains, the flattened windswept horizontal form can be seen in plants. The round, low ground-hugging plant forms can be seen on the rolling prairie. Such forms should be adhered to and predominantly used in local landscape plantings; this is one of the basic principles useful to the landscaper on the Plains.

Texture. Texture is a plant's quality of coarseness or fineness of appearance. Seen close up, texture is shown by size, surface and spacing of leaves and twigs at different seasons. At a distance, texture is the entire mass effect of plants and the quality of light and shadow. The patterns created by light and shade are an important part of texture. The gradation of texture in plants is expressed from fine to medium to coarse. Too much texture uniformity results in monotony; contrast can be obtained through variations, but extremes should be avoided. Texture changes with each season and is experienced differently even throughout the day.

Color. Color in the landscape is a very important factor. The Great Plains do not have the abundance of fall color as seen in our deciduous northern woods; the colors are more subdued, but do change with the seasons. In general, reds, oranges, and yellows are considered warm colors and seem to advance toward the viewer. Green and blue seems to recede in a composition. Dark blue, a cool color, would be suitable as a background color to increase the feeling of depth. Gray is a neutral color and is best used in the background when bright colors are used in the foreground. The Plains landscaper has more choices than might be thought but the initial problem is the apparent lack of color in the landscape. The color we see in the landscape is affected by the reflective values of the surfaces, by the quality of light, by the color reflections of adjacent objects and by shadows. The play of light in the Plains adds considerably to the range of color available to the landscaper.

A harmonious color design is most easily obtained by providing a dominance in one color. Colors of all the aspects of the composition should be considered, plant materials, as well as structures. When fences, pavements and building have a neutral color, they

appear smaller and farther away. Now the plants and resulting space become dominant in the composition. You must decide which elements will be dominant and which will be subordinate in each landscape that you develop. If each element had equal importance, the result is visual chaos. Conversely, if every element is subordinate, the result is monotony. It is planned contrast between the two extremes that gives a “spark” to design.

Where many of the arts move in the realm of three dimensions (height, width and depth) landscape design has a fourth, which is time. The element of time is more important than the other three because the material you work with is never static. Plants take time to grow and, in time, die. The lifespan of trees is often longer than that of man and, in many instances, longer than the buildings created today. Trees grouped together, in time, develop character. Trees exposed to wind will grow differently from those given shelter. Our ultimate conception of our composition, as far as it depends on trees, may take up to fifty years to mature. Sometimes it is possible to reduce planning to

an almost three-dimensional problem by using already well developed trees and shrubs with the help of mechanical methods. The use of large semi-mature plants may have advantages. The ultimate results are not the same and are less satisfactory than traditional methods. This is particularly true in the case of shelter planting. The pleasure of watching things develop and of noting and enjoying each different phase as it appears, is not to be relinquished lightly. To miss out on these intermediate stages is to lose one of those contacts with the soil which we can ill afford. The artificial completion of the project at one stroke is one of those means by which civilization impoverishes the realities of living. Vegetation, one of the essential components of landscape, is, thus, an everchanging material.

Early in this chapter we defined landscaping, now at the end we repeat: A landscape is the arrangement of plant material using its form, texture and color to create special effects. Good landscaping can create a sense of privacy or a feeling of having been somewhere special. (Figure 26)

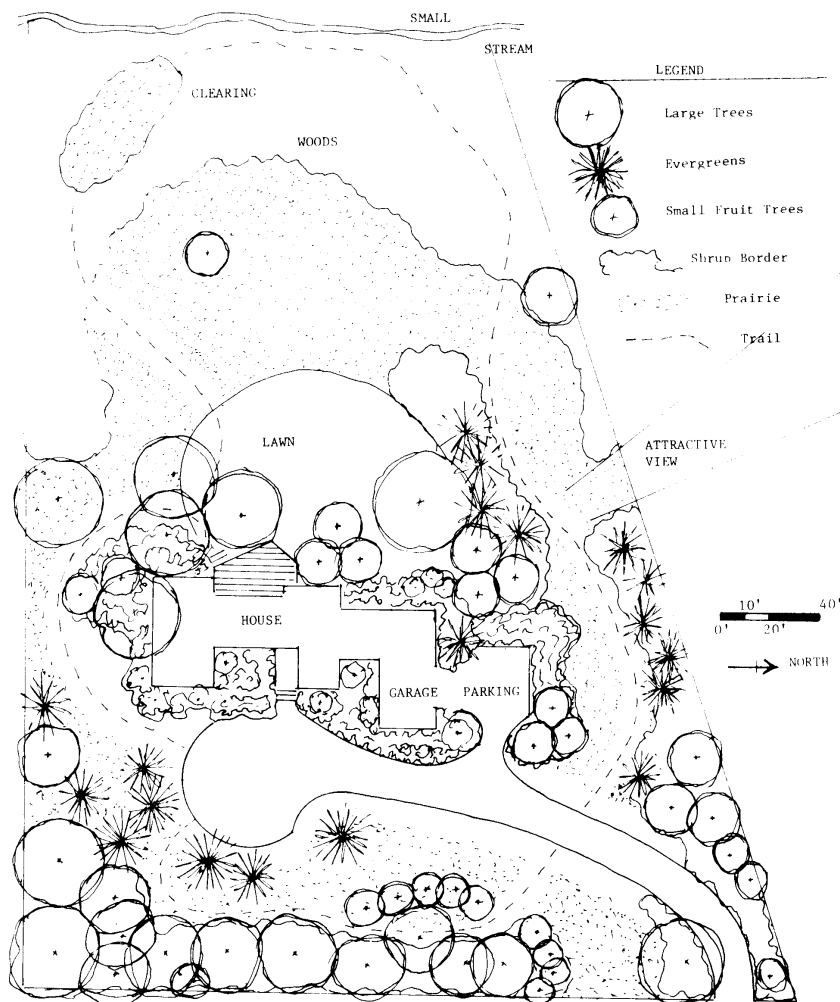

Figure 26. An urban home surrounded by hard woods, evergreens, shrubs, vines, grasses, forbes and even “weeds.” Use is made of massed planting and open space providing mass and void. The small clearing in the woods is especially attractive to birds.

Hedge Rows

The wide hedge row or wind break is an important habitat for wildlife which Aldo Leopold called “farm game.” Cover is provided for pheasant and quail which share the space with such animals as rabbits, squirrels, chipmunks and occasionally deer. In the winter, shelterbelts serve wildlife as travel lanes. From the following diagrams, you can make your own composition of hedgerow—selecting only the smaller species—to a complete windbreak including the taller trees.

A 20- to 25-foot row spacing is generally adequate. In row, spacing will vary with type of plant and soil. Shrubs 3 to 6 feet, Red cedar or juniper 8 to 12 feet, pine 10 to 16 feet, short deciduous trees 8 to 12 feet, and tall deciduous trees 12 to 18 feet. Use close spacing for hedgerows with only one or two rows. The wider spacings are best for multiple row windbreaks. Do not let a hedgerow stop abruptly but scatter some shrubs and small trees near the end to make the change less formal.

3-Row Windbreak

Wind →



* Note: A four-row windbreak can be made from the above by adding a shrub row (See listing of shrubs below.)

Row 1

Redcedar
Austrian Pine
Ponderosa Pine
Scotch Pine

Row 2

Cottonwood
Honeylocust
Hackberry
Silver Maple
Walnut
Oak
Catalpa

Row 3

Russian Olive
Russian Mulberry
Redbud
Apricot
Osage Orange
Green Ash
Black Locust

5-Row Windbreak

Wind →



Row 1

Multiflora Rose
Common Lilac
Honeysuckle
Chokecherry
Nanking Cherry
American Plum
Sandcherry
Winterberry
Fragrant Sumac
Autumn Olive

Row 2

Redcedar
Austrian Pine
Ponderosa Pine
Scotch Pine

Row 3

Russian Mulberry
Catalpa
Green Ash
Black Locust
Oak

Row 4

Cottonwood
Honeylocust
Hackberry
Silver Maple
Walnut
Oak
Catalpa

Row 5

Russian Olive
Russian Mulberry
Redbud
Apricot
Osage Orange
Green Ash
Black Locust

Plants

Following is a list and brief description of some plants which provide food and help create attractive habitat for song birds.

CRABAPPLE, *Malus spp.*

Bird Use: 24 species

Ornamental values: Many kinds; deciduous trees, 10–20 feet tall; white to pink flowers; red, purple, orange, or yellow fruit vary in size

Adaptations: Wide range of well-drained soils; sun

In bloom: March–April

In fruit: September–January

Sources: Commercial nurseries, budding, grafting

SUMAC, *Rhus spp.*

Bird Use: 36 species

Ornamental values: Several kinds; deciduous shrubs, 3–8 feet high; pale to deep green leaves, turning red in fall; greenish flowers in spikes; fruit clustered, deep red at maturity

Adaptations: Wide range of well-drained soils; sun

In bloom: April–May

In seed: September–February

Sources: Commercial nurseries, wilding trans-plants, root cuttings

PYRACANTHA (FIRETHORN),

Pyracantha spp.

Bird use: 16 species

Ornamental values: Several kinds; evergreen shrubs, 5–10 feet high; glossy green leaves; fragrant white flowers; striking red to orange fruit

Adaptations: Wide range of moderately well-drained to well-drained soils; sun to partial shade

In bloom: April–May

In fruit: September–February (most frequent bird use in January–February)

Sources: Commercial nurseries

POKEBERRY, *Phytolacca americana*

Bird use: 37 species

Ornamental values: Large plant, 4–6 feet high; pale-green leaves; white flowers; purple fruit have large shiny black seeds; grows wild as weed

Adaptations: Moderately well-drained fertile soils in freshly disturbed areas

In bloom: March–June

In fruit: July–December

Sources: Wilding transplants, seeds

HAWTHORN, *Crataegus spp.*

Bird use: 19 species

Ornamental values: Many kinds; deciduous trees 10–18 feet tall; pale green leaves; abundant clustered, white flowers; persistent orange to red fruit

Adaptations: Deep, moderately well-drained to well-drained soils; sun to partial shade

In bloom: April–May

In fruit: September–February

Sources: Commercial nurseries, wilding trans-plants

HOLLY, *Ilex spp.*

Bird use: 28 species

Ornamental values: Many kinds; mostly evergreen; upright rounded shrubs, 3–8 feet high, to trees, 10–20 feet; dark green or variegated leaves, small whitish flowers; bright red, orange, yellow, or black fruit (persistent)

Adaptations: Moderately well-drained to well-drained soils; sun to shade—only eastern parts of Kansas

In bloom: March–May

In fruit: September–April

Sources: Commercial nurseries, wilding trans-plants, cuttings

ELDERBERRY, *Sambucus spp.*

Bird use: 51 species

Ornamental values: Several kinds; deciduous shrubs, 5 feet high; flat whitish flower clusters; red to purple black fruit

Adaptations: Moderately well-drained to well-drained soils; sun to partial shade

In bloom: May–July

In fruit: July–December

Sources: Commercial nurseries, wilding trans-plants

AMERICAN BEAUTYBERRY, *Callicarpa americana*

Bird use: 12 species

Ornamental values: Deciduous shrub, 3–5 feet high; inconspicuous bluish or pink flowers; bright purple fruit in rings around stem

Adaptations: Deep, moderately well-drained to well-drained soils; sun to partial shade

In bloom: April–May

In fruit: August–January

Sources: Commercial nurseries, wilding transplants, cuttings from 1-year-old wood

FLOWERING DOGWOOD, *Cornus florida*

Bird use of all dogwoods: 45 species

Ornamental values: Various forms; shrub

5–8 feet high, to small tree, 10–15 feet; deciduous leaves, red to bronze in fall; showy, white to pink bracts surrounding small, inconspicuous, bunched red fruit

Adaptations: Moist to well-drained soils; sun to shade (grows under larger trees)

In bloom: March–late April

In fruit: August–September

Sources: Commercial and state nurseries, wilding transplants, cuttings

SUNFLOWER, *Helianthus spp.*

Bird use: 46 species

Ornamental values: Several kinds; annual or perennial plants, 4–8 feet high; large showy yellow flowers; size of seed filled disks varies with species, needs careful placement for good landscaping

Adaptations: Wide range of soil conditions; sun

In bloom: June–September

Ripe seed: August–October

Sources: Commercial seed store, harvested wild seed

NANDINA, *Nandina domestica*

Bird use: 12 species

Ornamental values: Shrub, 5–8 feet high; dark-green leaves turning purple and scarlet in fall; leaves persist about 3 years; large clustered flowers; prominent scarlet-red fruit

Adaptations: Wide range of moderately well-drained to well drained soils; sun to partial shade

In bloom: April–June

In fruit: October–February

Sources: Commercial nurseries

AMUR HONEYSUCKLE, *Lonicera maacki*

Bird use: 19 species

Ornamental values: Fast-growing, dense, deciduous shrub, 8–12 feet high; persistent, leathery leaves; abundant small, white, fragrant flowers; red clustered fruit, raisinlike when dried, available all winter

Adaptations: Does best on deep, well-drained soils

In bloom: April–June

In fruit: September–October

Sources: Commercial nurseries, wilding transplants

AUTUMN OLIVE, *Elaeagnus umbellata*

Bird use: 25 species

Ornamental values: Large, spreading deciduous shrub, 8–16 feet high; gray-green leaves; abundant small, fragrant, yellow flowers; abundant scarlet fruit

Adaptations: Moderately well-drained to well-drained, upland soils; sun to partial shade

In bloom: April–May

In fruit: July–October (holds fruit into winter)

Sources: Commercial nurseries

WILD PLUM, *Prunus americana*

Bird use: 16 species

Ornamental values: Deciduous shrub, 6–12 feet high, to small tree, 15–20 feet; suited to fields, fence rows, and big yards; spreads by suckers to form clumps; fragrant pink to white flowers; persistent red or yellow fruit

Adaptations: Moderately well-drained to well-drained soils; sun

In bloom: March–May

In fruit: June–August

Sources: Commercial nurseries, wilding transplants

DOVE PROSO MILLET, *Panicum miliaceums*

Bird use: 30 species; all millets; 60 species

Ornamental values: Fast-maturing, summer annual grass; seed can be harvested for winter bird feeding

Adaptations: Moderately well-drained to well-drained fertile soils; sun

Planting dates: May–June

In seed: July–September

Sources: Commercial seed stores

CHERRY, *Prunus spp.*

Bird use: 47 species

Ornamental values: Many kinds; deciduous shrubs; 5–10 feet high, to trees, 15–35 feet; small fine-toothed leaves; showy white flower clusters or drooping spikes; small bright-red to black fruit

Adaptations: Moderately well-drained to well-drained soils; sun to partial shade

In bloom: April–May

In fruit: Variable with species, June–October

Sources: Commercial nurseries, wilding transplants

THORNY ELAEAGNUS, *Elaeagnus pungens*

Bird use: 9 species

Ornamental values: Robust, evergreen shrub, 6–8 feet high; narrow leathery green leaves silvery below; tiny, fragrant, silvery white flowers; light-red fruit speckled with silver

Adaptations: Moderately well-drained to well-drained soils; sun to partial shade

In bloom: October–November

In fruit: March–April

Sources: Commercial nurseries

REDCEDAR, *Juniperus virginiana*

Bird use: 22 species

Ornamental values: Coniferous tree (many varieties) 10–30 feet tall; dense green to bluegreen needles; small dusty blue, berrylike, fleshy cones

Adaptations: Moderately well-drained to well-drained soils

In bloom: April–May

In fruit: August–December

Sources: Commercial nurseries, wilding transplants

SILKY DOGWOOD, *Cornus amomum*

Bird use: 10 species

Ornamental values: Medium shrub—white flat flower clusters and blue fruit clusters bronze fall foliage, reddish-purple winter stems

Adaptations: Wet to dry soil; sun to light shade

In bloom: May–July

In fruit: August–September

Sources: Commercial nurseries, state nurseries, wilding transplants and cuttings

GRAY-STEMMED DOGWOOD, *Cornus paniculata*

Bird use: 16 species

Ornamental values: Thicket forming medium shrubs—small, flat, white flower clusters; white berries on pink stems

Adaptations: Well-drained to dry soil; sun

In bloom: May–June

In fruit: August–November

Sources: Wilding transplants and cuttings

AMERICAN CRANBERRYBUSH, *Viburnum trilobum*

Bird use: 34 species

Ornamental values: Upright tall shrub with maplelike foliage—showy, white, flat clusters of flowers; glossy scarlet fruit cluster

Adaptations: Deep, wet to well-drained soil, sun to light shade

In bloom: May–June

In fruit: September–February

Sources: Commercial nurseries, some state nurseries, wilding transplants or cuttings

BITTERSWEET, *Celastrus scandens*

Bird use: 10 species

Ornamental values: Twining vine with pale-green foliage—greenish flowers, bright-red berries in yellow or orange husks

Adaptations: Well-drained to dry soil, sun to light shade

In bloom: May–June

In fruit: September–December

Sources: Commercial nurseries, some state nurseries, cuttings

HIGHBUSH BLUEBERRY, *Vaccinium corymbosum*

Bird use: 36 species

Ornamental values: Medium shrub with dark-green leathery leaves—small greenish white blooms; bright blue berries; scarlet fall color

Adaptations: Wet to dry soil, acid soils; sun

In bloom: June–August

In fruit: July–October

Sources: Commercial nurseries, wilding transplants

MOUNTAIN ASH, *Sorbus spp.*

Bird use: 15 species

Ornamental values: Medium tree with attractive compound leaves—flat, white flower clusters; bright-red or orange berry clusters

Adaptations: Moist to dry soil; sun

In bloom: May–June

In fruit: August–March

Sources: Commercial nurseries, wilding transplants

REDOSIER DOGWOOD, *Cornus stolonifera*

Bird use: 19 species

Ornamental Values: Medium shrub—white blooms; white berries, red stems in winter

Adaptations: Wet to well-drained soil; sun to shade

In bloom: May–July

In fruit: July–September

Sources: Commercial nurseries, wilding transplants, cuttings

TATARIAN HONEYSUCKLE, *Lonicera tatarica*

Bird use: 17 species

Ornamental values: Large shrub—pink to yellow blooms; red berries

Adaptations: Well-drained to dry soil; sun to shade

In bloom: June–July

In fruit: July–September

Sources: Commercial nurseries

VIRGINIA CREEPER, *Parthenocissus quinquefolia*

Bird use: 37 species

Ornamental values: Ground or climbing vine—blue to black berries; red in fall

Adaptations: Moist to dry soil; sun to shade

In fruit: August–February

Sources: Wilding transplants, cuttings, commercial nursery

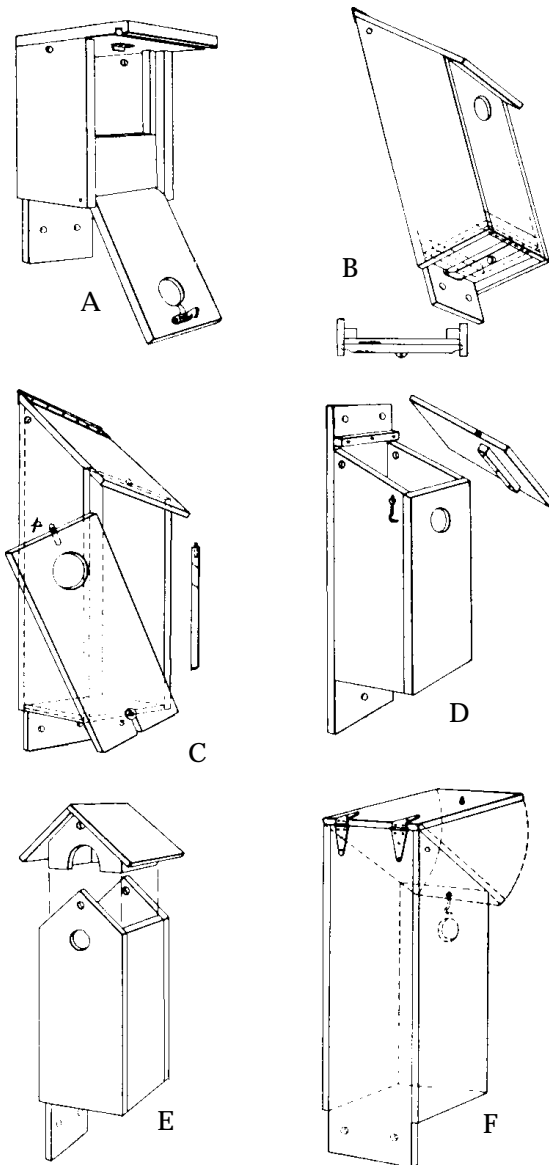

Figure 27. Accessible nest boxes: A, hinged front held up by a catch; B, removable bottom, released by the slight turn of a cleat; C, swinging front, held in place by the pine (P) and by tightening the screw (S); D and E, removable tops; F, hinged top.

Bird Houses

A well-designed bird house should be durable, rainproof, cool, readily accessible for cleaning, and also add beauty to its surroundings.

Most houses should be placed fairly low, should not be placed in dense woods, and seem more acceptable to the birds if they are placed on poles. Protect the houses from cats, squirrels, and other possibly harmful animals. If possible, place the house in partial sunlight with the opening away from prevailing winds. Provide drainage holes.

Limit the number of houses in one area as birds insist on territorial rights. The purple martin is the only bird that nests with many other families.

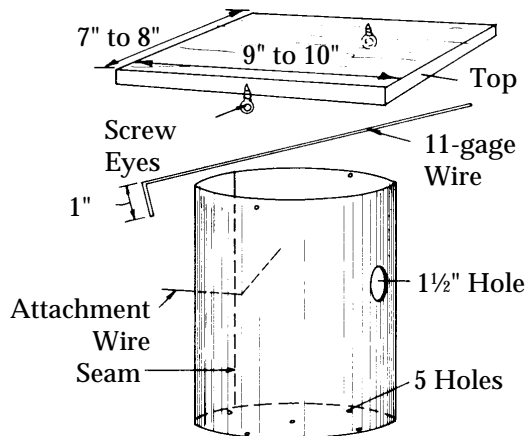

Figure 28. An easy birdhouse to make. The materials needed for this birdhouse are: a 2-quart tin can (7-inches tall and 6 inches in diameter), a 1 × 8 10 inches long, 2 screw eyes, an 8-inch length of 11 gauge wire.

Table 1. Bird House Dimensions.

Species	Floor Area Inches	Depth Inches	Entrance Above Floor Inches	Diameter of Entrance Inches	Height Above Ground Feet
Purple martin	6 × 6	6	1	2½	12 to 20
House wren	4 × 4	6 to 8	1 to 6	⅞ to 1	6 to 10
Carolina wren	4 × 4	6 to 8	1 to 6	1⅞	6 to 10
Bluebird	6 × 6	8	3 to 6	1½	5 to 10
Barn swallow	6 × 6	6	*	1½ to 2	8 to 12
Tree swallow	6 × 6	6	2 to 5	1½	10 to 15
Chickadee	4 × 4	6 to 8	6 to 8	1⅞	6 to 15
White breasted nuthatch	4 × 4	8 to 10	6 to 8	1¼	12 to 20
Phoebe	6 × 6	6	*	*	8 to 12
Red headed woodpecker	6 × 6	12 to 15	9 to 12	2	12 to 20
Hairy woodpecker	6 × 6	12 to 15	9 to 12	1½	12 to 20
Downy woodpecker	4 × 4	8 to 10	6 to 8	1¼	8 to 20
Flicker	7 × 7	16 to 18	14 to 16	2½	12 to 20
Screech owl	8 × 8	12 to 15	9 to 12	3½	10 to 30
Saw whet owl	6 × 6	10 to 12	8 to 10	3	12 to 20
Barn owl	10 × 18	15 to 18	4	6	12 to 20
Sparrow hawk	8 × 8	12 to 15	9 to 12	3	10 to 30
Robin	8 × 8	8	*	*	6 to 12
Mourning dove	8 × 8	8	*	*	6 to 12

*One to three sides open

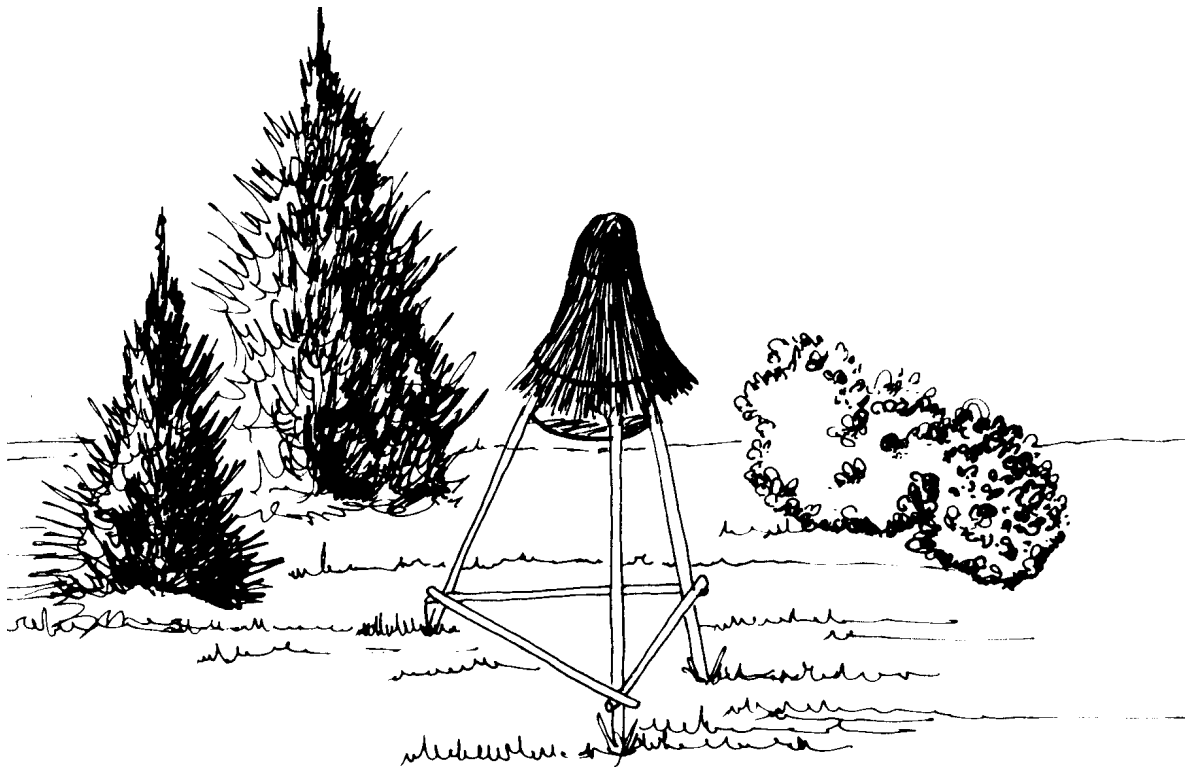

Figure 29. Bird feeder with a straw roof. Blends well with a natural environment.

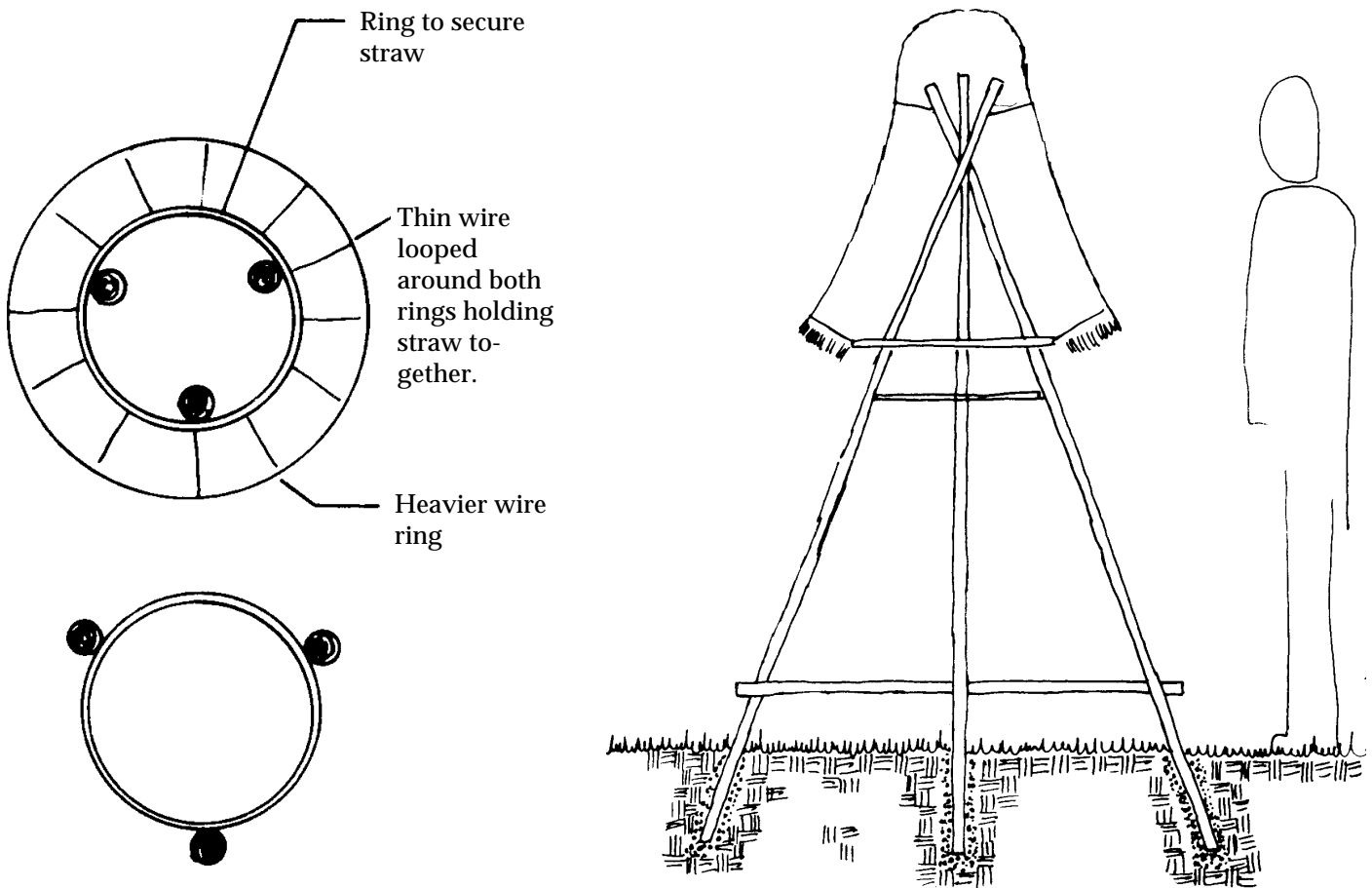
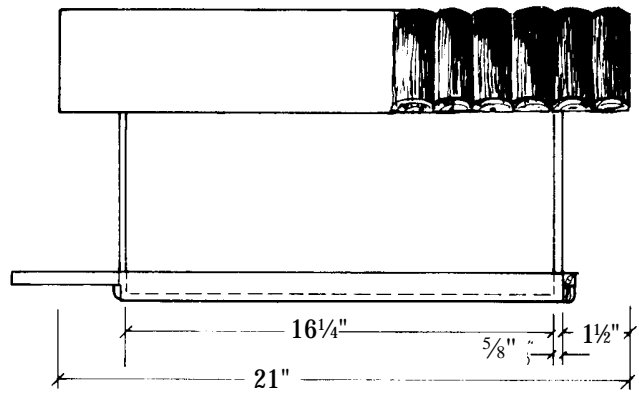
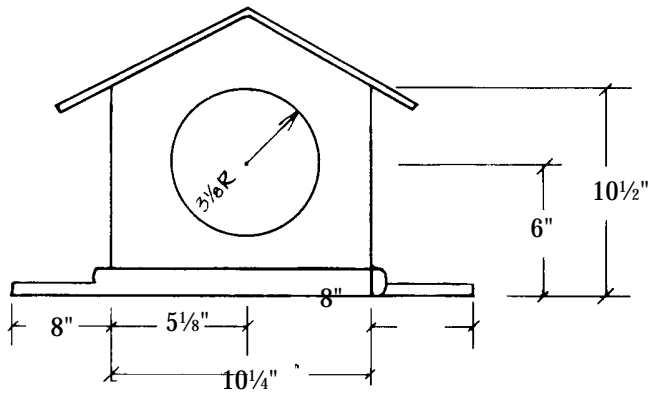

Figure 30. Feeding board with tin rim.



Front View



Side View

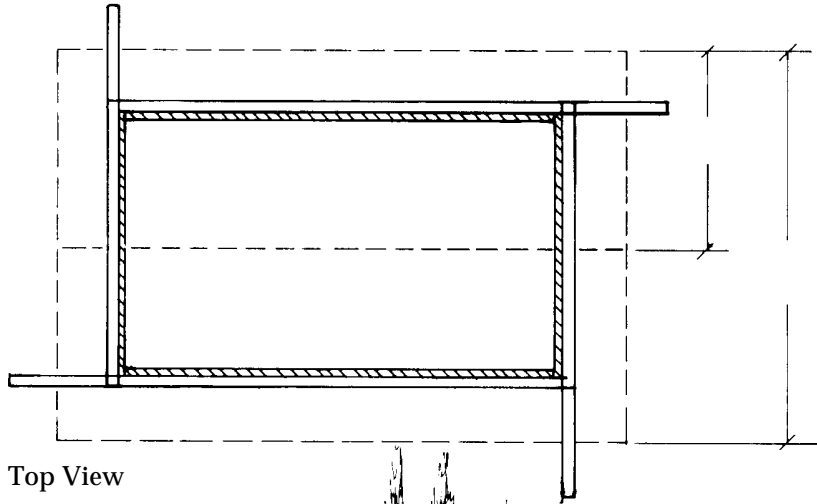

Top View

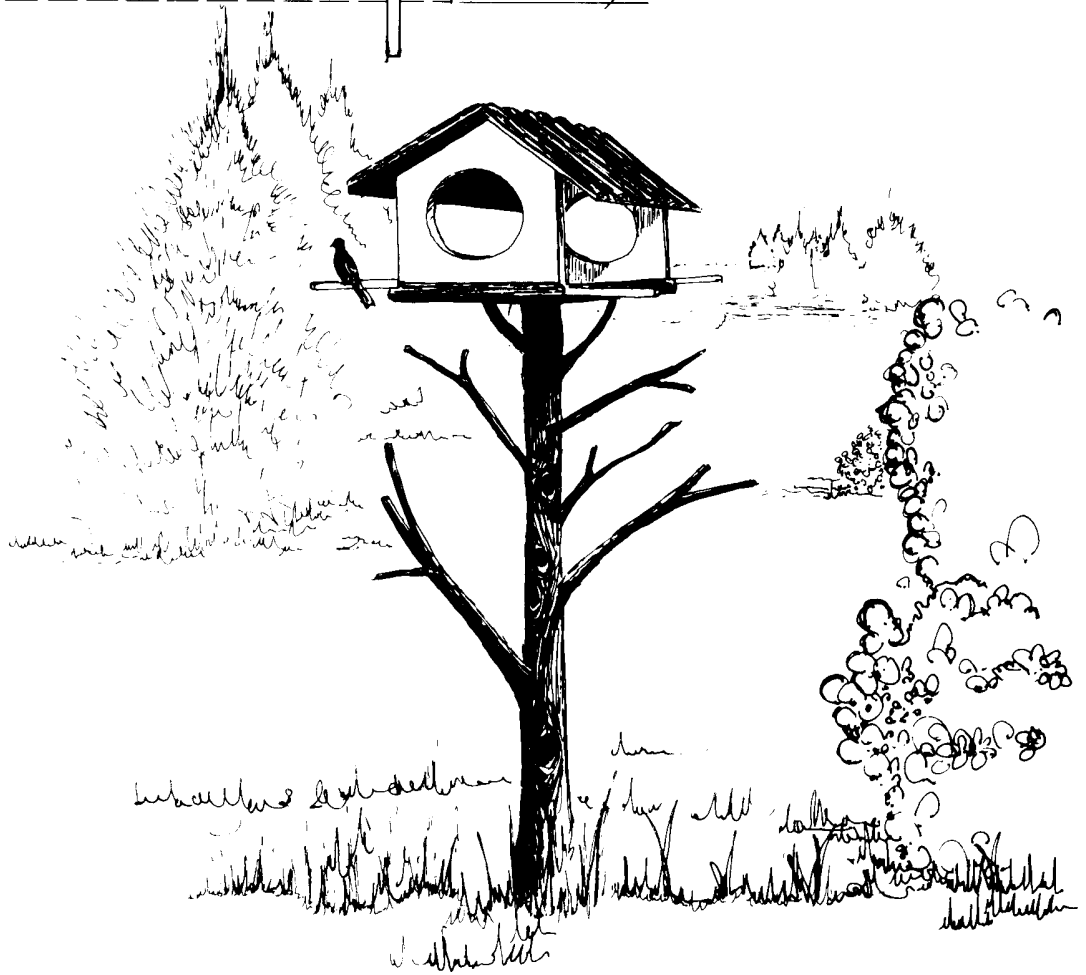

Earlier in this chapter we briefly discussed the "Web of Life" and the relation between its various components. For those of you who are interested in a closer look at this biotic community that surrounds us, we have included the following material here in this section.

Biotic Communities

The species of plants and animals that occupy the site of a proposed land development are more than just a loose collection of organisms that happen to occupy the same area. They combine and interact to form biological systems, known as biotic communities. To the casual observer, these community systems may appear to be static in nature. The prairie, for example, appears always to be the prairie, ever present and unchanging. Behind this mask of tranquility though, exists a system that is very dynamic and active and very well organized. The components within the systems (i.e., the different species of plants and animals) are interconnected by a complex web of interrelationships which serve as environmental feedback mechanisms, giving the system both a recycling and self-regulatory capacity, thus lending stability to it. For example, decomposer organisms (e.g., mites, bacteria, fungi, etc.) feed on dead organic matter (plant and animal) accumulating above and in the top layers of the mineral soil. In doing so, they make available nutrients locked up in this organic debris for reuse by the plants. They also prevent large accumulations of organic matter that would otherwise eventually choke out the living plants and animals and add humic particles to the soil, improving its water and nutrient holding capacity. Individual components of the system also exert regulatory influences on other components through their interrelationships. Thus, a mouse population is, in part, controlled by food and cover availability and predation. However, the concept of system self regulation should not be taken to imply strict individual component population levels. Rarely do species populations remain at any one level, rather they are constantly fluctuating between an indistinct high and low limit in response to regulatory factors, both within and external to the community. The primary reason for the fluctuations is the lag time involved in both the response of the regulating factors, and the relaxation of those regulating factors. While biotic communities possess internal recycling and regulatory mechanisms, both the community as a whole and individual components are subject to external controlling factors.

The abiotic factors existing at a site have a great deal to do with the type of biotic community that exists there. Generally, this control is exerted by those factors that limit what type of vegetation will be able to thrive on the site. Soil fertility, drainage, temperature extremes, length of growing season, and amount and frequency of precipitation are a few examples of limiting abiotic factors. Once they become established, however, biotic communities do have the ability to "fine tune" some of these abiotic factors by creating a microclimate within the community. Within a good-sized tree stand, for example, the humidity is higher, the wind

much lower, and the temperature fluctuations much lower than external to it.

There may also be external biotic factors affecting the components within the system. For example, species of one community may prey on species of another, thus becoming a regulating factor. This is particularly common where a patch work of different communities exist.

Environmental impacts begin at the component level. Once a component is impacted, (e.g., all mice have been killed) it may "transfer" that impact to other components via interrelationships it has with them. These components may, in turn, pass the impact on to still other components, and so on. In this way, a single impact can spread through a biotic community. This may have a dissipating effect or just serve to affect more components. When many components are affected simultaneously, the impact may tend to concentrate, through community interrelationships, on components not originally affected. Impacts may also be transferred from one community to another in the same manner as described above. So when modifying a site, even on a small scale, keep these facts in mind and try to retain biotic communities intact.

For further reading and ideas ask your Library for the following reading material.

A Sand County Almanac, by Aldo Leopold, Ballantine Books, Inc., New York. 1970.

The Prairie World, by David Costello, Thomas Y. Crowell Company, New York. 1975.

Ecology and Field Biology, by Robert L. Smith, Harper and Row Publishers, New York. 1966.

The Wild Gardener in the Wild Landscape, by Warren G. Kenfield, Hafner Publishing Company, New York. 1966.

A Guide to Nature in Winter, by Donald W. Stokes, Little, Brown and Company, Boston. 1976.

Prairie Plants and Their Environment, by J.E. Weaver, University of Nebraska Press, Lincoln, Nebraska. 1968.

Woody Plants of the North Central Plains, by H.A. Stephens, University Press of Kansas, Lawrence, Kansas. 1973.

Trees, Shrubs and Woody Vines in Kansas, by H.A. Stephens, University Press of Kansas, Lawrence, Kansas. 1969.

Nebraska Wild Flowers, by Robert C. Lommasson, University of Nebraska Press, Lincoln, Nebraska. 1973.

Missouri Wildflowers, by Edgar Denisen, Missouri Department of Conservation, 1973.

Field Guide to the Birds, by Roger Tory, Peterson Houghton Mifflin Company, Boston.

The Life of Birds, by Joel Carl Welty, W.B. Saunders Company, Philadelphia. 1962.







Brand names appearing in this publication are for product identification purposes only. No endorsement is intended, nor is criticism implied of similar products not mentioned.

Publications from Kansas State University are available on the World Wide Web at: <http://www.oznet.ksu.edu>

Contents of this publication may be freely reproduced for educational purposes. All other rights reserved. In each case, credit Gustaaf A. van der Hoeven, *Naturalistic Landscaping*, Kansas State University, August 1977.

Kansas State University Agricultural Experiment Station and Cooperative Extension Service

C-581

August 1977

It is the policy of Kansas State University Agricultural Experiment Station and Cooperative Extension Service that all persons shall have equal opportunity and access to its educational programs, services, activities, and materials without regard to race, color, religion, national origin, sex, age or disability. Kansas State University is an equal opportunity organization. Issued in furtherance of Cooperative Extension Work, Acts of May 8 and June 30, 1914, as amended. Kansas State University, County Extension Councils, Extension Districts, and United States Department of Agriculture Cooperating, Marc A. Johnson, Director.

File Code: Horticulture and Landscaping-6