

# Getting the Most from Your Tractor

**Randy Taylor**

Extension Agricultural Engineer

**Mark Schrock**

Associate Professor

**Kelly Wertz**

Kearny Co. Extension Agent, Agriculture

Department of Agricultural Engineering

**N**ow more than ever, producers need to operate tractors more efficiently. With agriculture becoming increasingly competitive, it is simply good business to accomplish more work with less time and fuel. To achieve this goal, you must first understand how a tractor transfers power to the ground and then how to ensure your tractor is transferring power efficiently. Few people realize how much power a tractor can lose during field operation.

Consider a two-wheel-drive tractor that produces 150 PTO horsepower. The first power loss occurs in the transmission and usually amounts to about 4 percent. This means only 144 horsepower is actually available at the rear axle. The next power loss, between the tires and soil, is the one that concerns us. The amount of power lost depends mainly on soil conditions, tires, and weight on the tires. Figure 1 shows tractive efficiency, the ratio of drawbar power to axle power, on several soils at various slip rates for two-wheel-drive tractors. A lower tractive efficiency indicates lower drawbar power since axle power remains fairly constant at rated engine speed. Notice that for firm soil (such as the first operation after harvest) the most we can expect is about 78 percent efficiency at about 10 percent wheel slip. The example tractor, if operated correctly, could produce approximately 112 drawbar horsepower on firm soil.

What happened to other 32 horsepower? The engine burned the fuel needed to produce it, and the transmission applied it to the rear axle, but 32 of the original 144 horsepower was lost at the soil surface. Power was lost to wheel slippage and rolling resistance. Wheel slippage is simply the tire spinning. Rolling resistance is the resistance of the tire's movement through the soil.

Slippage is reduced by adding weight to the tractor, but you should be careful not to add too much weight. Slippage acts as a safety clutch for the drivetrain, limiting the torque that can be transmitted through it. Excess weight also increases rolling resistance of the tires dramatically which in turn will rob power. Both losses occur anytime a tractor is operated in the field, but they can be reduced by careful operation of the tractor. Properly weighting a tractor will ensure an efficient compromise between the two.

In our example, if the tractor is

improperly weighted and operating at 5 percent slip, rolling resistance reduces tractive efficiency from 78 to 73 percent. On the other hand, if the tractor is too light and slippage is 17 percent, tractive efficiency is also 73 percent. As the curves in Figure 1 show, tractive efficiency drops faster for slips below 10 percent than for slips above 10 percent.

Achieving optimum efficiency involves matching weight and speed to the tractor's power and operating conditions. Notice from Figure 1 that best efficiency usually occurs when slippage is between 8 and 15 percent, depending on soil conditions. Choosing the right amount of weight and speed for a given tractor is the first step toward optimum performance. The primary factors that dictate weight requirements and operating speed are implement draft,

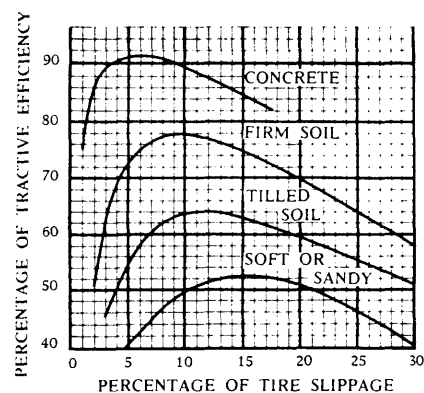

**Figure 1. Tractive efficiency for various soils and tire slippage (2WD tractors).**



type of implement, and soil conditions.

Draft is the force required to pull the implement through the soil and is related to available power and speed. For example, if our 150 PTO horsepower tractor is operating in firm soil, at 6 mph, the 112 drawbar horsepower can generate about 7,000 pounds of pull. However, if the tractor is to produce the same 112 drawbar horsepower at 4 mph, the draft must be about 10,500 pounds. The slower tractor needs more weight on the drive wheels to maintain acceptable slippage.

Mounted and semi-mounted implements transfer weight to the tractor by pulling down on the rear hitch. Less weight is needed on the rear axle to pull them, but more weight is needed on the front axle for stability. If the same tractor is used for many different tasks, the implements should be matched carefully to the weight of the tractor. That is, the heavy draft, low speed implements should be purchased in mounted or semi-mounted configuration so that additional ballast will not be necessary to control slippage.

If the tractor will usually be operated within a certain speed range, the proper amount of weight can be estimated using Table 1. An important assumption was made to get the numbers in Table 1. Tractors seldom operate at full engine load, and ballast depends on the amount of horsepower actually used in field operations. To satisfy varying load patterns, these numbers are based on an 80 percent load and give only an approximation of the optimum weight. The estimated weights in

**Table 1. Optimum total tractor weight.**  
pounds per PTO horsepower

Speed	2WD	FWD & 4WD
4	160	140
5	135	115
6	110	95

Table 1 are a good starting place; the tractor should be fine-tuned under field conditions with the particular implement.

The weight shown in Table 1 is given in pounds per rated PTO horsepower. For example, if a 2WD tractor will be used at 5 mph, it should have 135 pounds/PTO horsepower total weight on the tractor. Generally, 75 percent of the weight belongs on the rear axle and 25 percent on the front. However, on many 2WD tractors, more ballast is needed on the front of the tractor to maintain control during field work and transport. Excessive front weight increases the rolling resistance, while insufficient front weight reduces control and creates a safety hazard. Proper distribution of weight can have a significant impact on tractor performance. Table 2 shows proper weight distribution for tractor and implement arrangements.

Now considering the example tractor, it should have a total weight of 20,250 pounds (150 PTO HP X 135 pounds/PTO HP = 20,250 pounds) for 5 mph. Checking Table 2, about 5,050 pounds (25% of 20,250) should be on the front axle and about 15,200 pounds (75% of 20,250) should be on the rear axle. Naturally, we don't need to be this precise. If the tractor had 5,000 pounds on the front axle and 15,000 pounds on the rear axle, it would be close. Use Table 1 to estimate optimum weight, especially when purchasing a new tractor. Then

**Table 2. Optimum weight distribution percentages.**

Tractor/Implement	Front Axle	Rear Axle
2WD/Towed	25	75
2WD/Semi-mounted	30	70
2WD/Mounted	35	65
FWD/Towed	40	60
FWD/Mounted	45	55
4WD/Towed	55	45
4WD/Mounted	60	40

adjust weight as needed after measuring wheel slippage.

Tractors used at speeds greater than 6 mph are probably ballasted correctly from the factory. In fact, most FWD or 4WD tractors have a shipping weight greater than 95 pounds/PTOHP.

When adding duals to a tractor, the weight of dual tires must be added into the total weight of the tractor. Dual tires can add a significant amount of weight to the tractor. Heavy cast or light steel hubs and wheels can be used on most tires, so the type of wheels and hubs used can significantly vary the amount of weight added with each tire.

To determine the weight of your present tractor, drive the tractor on a platform scale and read the total weight. Then weight each axle separately to get the weight distribution. When the total, ballasted tractor weight has been determined, consult the operator's manual or the ROPS (Roll Over Protective Structure) certification tag attached to the cab for the maximum working weight. The ROPS is designed for a maximum tractor weight and may fail if the ballasted tractor weight exceeds this limit. Make sure the total tractor weight is below the ROPS limit.

High draft, low speed operations place greater stress on tractor drive trains, so weighting a tractor for operation below 4 mph is not recommended. Some manufacturers place the minimum speed above 4 mph, so check the owner's manual for more information.

Once a tractor has left the dealership, it is unlikely that ballasting changes will ever be made. Remember that it is more expensive to correct ballasting and tire problems after the tractor is in the field. Proper tractor configuration before it leaves the dealership is the most effective way of assuring maximum performance. The preceding guidelines should help to ballast the tractor properly.

## Type of Weight

The two most common types of ballast are cast iron and calcium chloride solution. In terms of tractive performance, there is no significant difference between the two. The greatest differences are in initial cost and convenience of adjusting tread width. Cast iron weights are more expensive than chloride solution and occupy extra space on the axle. They may complicate the process of changing tread width.

If calcium chloride or some other fluid solution is used, the tire should be filled no more than three-fourths full. This corresponds roughly to the valve level when the valve is at the top of the tire. Leaving this air pocket allows some cushion in the tire and reduces the chances of bruise damage. Calcium chloride can corrode tubeless rims if the rim is not completely covered with solution (about 90 percent fill) when the tractor is parked. However, filling the tire to 90 percent reduces the air pocket in the tires. If corrosion presents a problem, a water and antifreeze mixture can be used.

Liquid ballast has an effect on inflation pressure that is often overlooked. In most cases, the inflation pressure of a fluid filled tire is checked with the valve stem at the top in order to sample the air. However, the column of fluid in the tire adds pressure to the bottom of the tire. As shown in Figure 2, each

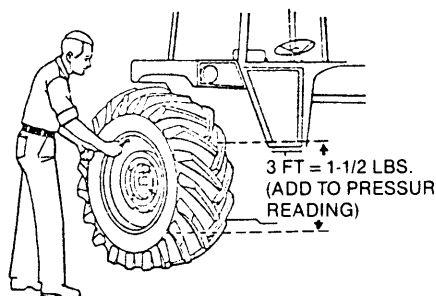

**Figure 2. Correcting for the column of liquid ballast when checking tire pressure.**

foot of fluid height equals about  $\frac{1}{2}$  psi pressure. Since most tires have about 3 to 4 feet of fluid in them, this can easily make 2 psi difference. Thus, if 16 psi are needed at the bottom of the tire, the gauge at the top of the tire should read about 14 psi. Remember to check tire pressures often. With the small air pocket in fluid filled tires, a minimal air loss can result in significant pressure loss.

Fill only the inside duals with ballast. Ballasted outer duals are difficult and dangerous to handle if they are removed for certain field operations. Ballasting non-powered front tires is not recommended because of possible steering and control problems, especially at transport speeds.

## About Tires

Tires are another major factor in determining tractor performance. The maximum load that a tire can carry depends on inflation pressure and the ply rating or star marking. Although more load can be carried at higher inflation pressures, tractive performance will usually suffer. Reduced load and lower inflation pressure both tend to cut compaction and improve performance, so it is usually best to operate tractor tires at the lowest pressure that produces satisfactory durability.

When dual tires are used, the inflation pressure should be at least 12 psi in the outer tire with the inner tire 2 psi higher. Reduced tire pressures with duals should help improve performance. However, the load carried by each tire should not exceed the maximum load at the lower pressure. Maximum loads for dual tires are 88 percent greater than when singles are used, not 100 percent greater.

What about tire construction? Radial ply tractor tires offer some advantages over bias ply tires that deserve consideration when new tires are being selected for farm tractors.

Radial tractor tires generally provide better traction than bias tires with similar tread design. Improved traction from radial tires generally results in a 2 to 6 percent increase in productivity and a 6 to 8 percent reduction in fuel consumption. Provided that draft load on the tractor remains the same, radial tractor tires will generally help you cover more acres per hour while reducing the gallons per acre of fuel used.

## What About Front Wheel Drive?

Until now, this fact sheet has dealt mainly with 2WD tractors. What about front wheel drive (FWD) tractors? Front wheel drive tractors are different from two wheel drive tractors in that the front tires are pulling a portion of the load. The amount of pull the front tires offer depends on the weight on the tires.

The difference in ballasting requirements stems from the fact that with FWD tractors, the drive wheels carry the total weight. With a 2WD tractor, some weight is transferred from the non-driving (front) wheels to the driving (rear) wheels when the tractor is under load. Thus, when operating, the rear wheels of the 2WD may carry 120 percent of the original static load. However, there is still some weight holding the front axle down for steering. This weight offers no benefit for traction purposes. The same type of weight transfer also occurs in FWD tractors, but in this case it is simply shifted from one set of driving wheels to another. For practical purposes, the total weight on both sets of the drive wheels does not change when these tractors are under load.

Ideally, FWD tractors should carry 40 percent of their weight on the front tires and 60 percent on the rear when the tractor is stationary (Table 2). Front weight should be increased to about 45 percent for semi-mounted and mounted imple-

ments. Since front tires are driven and carry more weight than comparable 2WD tractors they create a better track for rear tires. The compacted track increases the traction of the rear tires. Although FWD tractors are often fitted with dual tires, this practice is controversial. It is not recommended for FWD tractors with less than 140 PTO horsepower. When FWD tractors are equipped with duals the inside tire operates in the compacted track of the front tire while the outside tire is left to pack its own track. This increases the rolling resistance of the outside tire since the tire must climb over additional soil. The outside tire also may lift the inside tire slightly and reduce its ability to benefit from the firm track left by the front tire. FWD tractors over 140 PTO horsepower can benefit from dual rear tires. In fact, duals may be required to carry the weight needed to transfer this horsepower to the ground. Duals will also improve stability and ride. Since dual tires are not usually recommended for FWD tractors, it is a good idea to choose single tires large enough to carry the needed weight.

### What About 4WD?

Most of the same principles that apply to 2WD tractors are still relevant, but 4WD tractors require slightly different ballasting practices. Four wheel drive refers to all tractors with equal size front and rear drive tires. Most standard equipped 4WD tractors are heavier and have more tire capacity than comparable 2WD tractors. In some cases, the four wheel drive will be ready for field work at its standard factory weight.

Ideally, a 4WD tractor should have over 50 percent of the total weight on the rear tires when pulling a load. Thus, when stationary, the tractor should have 55 to 60 percent of its weight on the front wheels (Table 2). The draft force from the implement will transfer some of this weight to the rear axle.

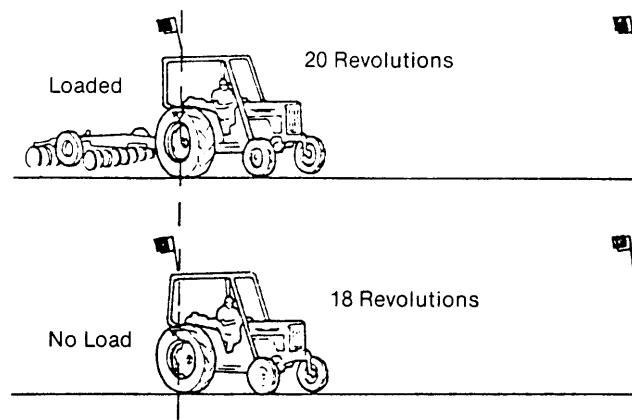

**Figure 3. Measuring wheel slip (2WD and 4WD).**

1. Choose a field and working conditions that are typical of those most often encountered. Operate the tractor in the same gear and throttle setting as usual.
  2. Position the starting stake at an arbitrary point.
  3. With the tillage tool in the ground, drive the tractor past the starting stake and note the position of the valve stem. Be sure to allow enough extra space to get the tractor up to speed before it crosses the starting point. If the valve stem is difficult to see, you may need to mark the tire with chalk.
  4. Walk alongside the tractor and count 20 full revolutions of the tire. Place the finish stake at this point. Be careful to stay out of the implement's path.
  5. Circle back with the tractor and raise the tillage tool out of the ground. Use the same gear, and do not drive in the previously worked ground. Note the position of the valve stem when the tractor passes the starting stake.
  6. Again, walk alongside the tractor and count the wheel revolutions needed to cover the distance between the stakes.
  7. Calculate the percent slip from Table 3.
- Example:* It took 16 turns to cover the distance without load. From column 2 in Table 3 the slip is 20 percent.

As with 2WD tractors, the best way to ensure good performance is to check slippage under field conditions, but Table 1 can be used to estimate the total weight requirement for 4WD tractors.

### Measuring Wheel Slip

Few people realize how easy it is to measure slippage. Slippage can be checked in 10 minutes, and it could point out problems that may be costing you 20 horsepower or more. Two people are needed, but the only

equipment necessary is two stakes (see instructions, Figure 3).

**Table 3. Slip percentages for 20 tire revolutions under load.**

No Load %		Corrective Action
Revolutions	Slip	
20	0	Remove ballast
19	5	Remove ballast
18	10	None
17	15	None
16 or less	20 or more	Add ballast

If help is unavailable, you can usually estimate slippage by stopping the tractor under load and checking tire tracks. At acceptable wheel slips the tire track should be sheared about one half of the lug width with soil in the center portion of the track crumbled. The photos in Figure 4 show tracks at 15 and 22 percent slippage. If slippage is less than 8 percent, shear will not be noticeable and the track will not be deformed and appear very clear. At higher wheel slips, the track will be wiped clean.

What are reasonable limits for slippage? Remember, maximum efficiency occurs at about 10 percent slip on firm soil and 15 percent on soft soil. If slippage is less than 10 percent, weight should be removed from the tractor to reduce compaction and rolling resistance in soft soils. If slippage is over 15 percent additional weight will usually be needed to increase efficiency. A good number to shoot for is 12 percent.

Before adding weight to an existing tractor, make sure the tires are not already overloaded or ROPS limits are not exceeded. If you don't know the weight of your tractor check it using the guidelines discussed previously.

Tractor ballasting is not an everyday task, but time spent to properly ballast a tractor is essential to ensure efficient operation.

Invest a little time making sure your tractor is operating efficiently and see if you save time and fuel.

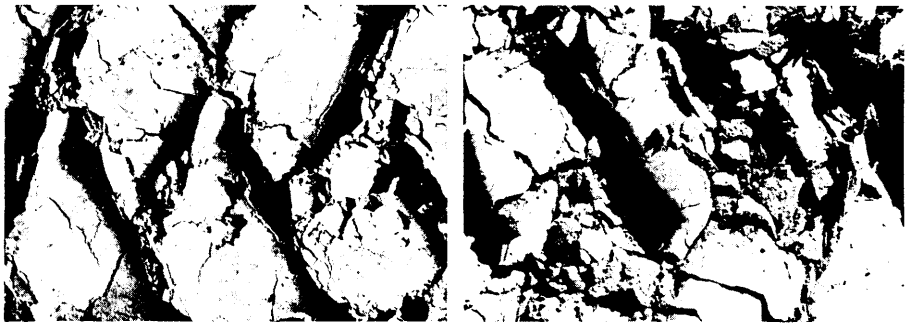

Figure 4. Photographs show tire tracks at 15 percent (left) and 22 percent slippage.

If the soil has adequate moisture, tire tracks can be used to estimate wheel slip. Simply stop the tractor and check the tracks in front of the tillage tool. If slip is too high, the track will be broken up and if slip is too low, it will be very defined. Tracks should be slightly broken with the lug pattern still defined. Reducing wheel slip from 22 to 15 percent will save about one hour of operating time and expense in a 10-hour work day.



**Cooperative Extension Service, Kansas State University, Manhattan**

Issued in furtherance of Cooperative Extension Work, acts of May 8 and June 30, 1914, as amended. Kansas State University, County Extension Councils, Extension Districts, and U.S. Department of Agriculture Cooperating, Richard D. Wootton, Associate Director. All educational programs and materials available without discrimination on the basis of race, color or, national origin, sex, age, or disability.

Revised April 1991

File Code: Engineering—3 (Machinery); 4-91—3M; 4-95—1